

# INSTALLATION INSTRUCTIONS

**\*SA(1,2)BD4M1 SERIES - (S,R)N18K, (S,R)N24K, (S,R)N30K, (S,R)N36K, SN42K, SN48K, & SN60K (1.5, 2, 2.5, 3, 3.5, 4, & 5 TON) - SINGLE PHASE MODELS**

<b>IMPORTANT SAFETY INFORMATION.....</b>	<b>2</b>	<b>START UP &amp; ADJUSTMENTS .....</b>	<b>7</b>
<b>AIR CONDITIONER INSTALLATION.....</b>	<b>3</b>	Pre-Start Check List.....	7
General Information .....	3	Start-Up Procedures .....	7
Before You Install this Unit.....	3	Air Circulation - Indoor Blower .....	7
Locating the Air Conditioner.....	3	System Cooling.....	7
Packaging Removal .....	3	System Heating (optional) .....	7
Ground Level .....	3	<b>REFRIGERANT CHARGING .....</b>	<b>7</b>
Roof Mount .....	3	Charging the Unit in AC mode .....	8
Connecting Refrigerant Tubing Between the		If the outdoor temperature is 65 degrees F	
Indoor & Outdoor Unit.....	4	or higher:.....	8
<b>ELECTRICAL WIRING .....</b>	<b>4</b>	If the outdoor temperature is below 65	
Pre-Electrical Checklist.....	4	degrees F:.....	8
Line Voltage .....	4	<b>ELECTRICAL DIAGRAMS &amp; TABLES .....</b>	<b>9</b>
Grounding .....	5	Figure 5. Wiring Diagram for *SA(1,2)BD4M	
Comfort Alert™ Diagnostics Module .....	5	(1.5, 2, 2.5, 3, 3.5, 4, & 5 Ton Units) ....	9
(Select Models Only).....	5	Figure 6. Wiring Diagram for *SA(1,2)BD4M1RN	
24 VAC Power Wiring.....	5	(1.5, 2, 2.5, & 3 Ton Units).....	10
Thermostat Demand Wiring.....	5	Table 1. Comfort Alert LED Diagnostics.....	11
Interpreting the Diagnostic LED's .....	5	Table 2. Module Wiring Troubleshooting .....	12
LED Description.....	5	<b>INSTALLATION CHECKLIST.....</b>	<b>16</b>
Thermostat Connections.....	6	<b>REPLACEMENT PARTS .....</b>	<b>16</b>
<b>AIR CONDITIONER MAINTENANCE.....</b>	<b>6</b>		
Panel Removal.....	6		
Panel Installation.....	6		

## IMPORTANT

### ATTENTION INSTALLERS:

It is your responsibility to know this product better than your customer. This includes being able to install the product according to strict safety guidelines and instructing the customer on how to operate and maintain the equipment for the life of the product. Safety should always be the deciding factor when installing this product and using common sense plays an important role as well. Pay attention to all safety warnings and any other special notes highlighted in the manual. Improper installation of the unit or failure to follow safety warnings could result in serious injury, death, or property damage.

These instructions are primarily intended to assist qualified individuals experienced in the proper installation of this appliance. Some local codes require licensed installation/service personnel for this type of equipment. Please read all instructions carefully before starting the installation. Return these instructions to the customer's package for future reference.

**DO NOT DESTROY. PLEASE READ CAREFULLY & KEEP IN A SAFE PLACE FOR FUTURE REFERENCE.**

## IMPORTANT SAFETY INFORMATION

**INSTALLER:** Please read all instructions before servicing this equipment. Pay attention to all safety warnings and any other special notes highlighted in the manual. Safety markings are used frequently throughout this manual to designate a degree or level of seriousness and should not be ignored.

**WARNING** indicates a potentially hazardous situation that if not avoided, could result in personal injury or death.

**CAUTION** indicates a potentially hazardous situation that if not avoided, may result in minor or moderate injury or property damage.

---

### **WARNING:**

---

**Shut off all electrical power to the unit before performing any maintenance or service on the system. Failure to comply may result in personal injury or death.**

---

---

### **WARNING:**

---

**Unless noted otherwise in these instructions, only factory authorized parts or accessory kits may be used with this product. Improper installation, service, adjustment, or maintenance may cause explosion, fire, electrical shock or other hazardous conditions which may result in personal injury or property damage**

---

---

### **WARNING:**

---

**\*SA(1,2)BD4M Split System Air Conditioners are shipped charged with R410A refrigerant and ready for installation. If repairs make it necessary for evacuation and charging, it should only be attempted by qualified trained personnel thoroughly familiar with this equipment. Under no circumstances should the owner attempt to install and/or service this equipment. Failure to comply with this warning could result in property damage, personal injury, or death.**

---

---

### **CAUTION:**

---

**This unit uses refrigerant R-410A. DO NOT use any other refrigerant in this unit. Use of another refrigerant will damage the unit.**

---

---

### **WARNING:**

---

**The information listed below must be followed during the installation, service, and operation of this unit. Unqualified individuals should not attempt to interpret these instructions or install this equipment. Failure to follow safety recommendations could result in possible damage to the equipment, serious personal injury or death.**

---

- The installer must comply with all local codes and regulations which govern the installation of this type of equipment. Local codes and regulations take precedence over any recommendations contained in these instructions. Consult local building codes and the National Electrical Code (ANSI C1) for special installation requirements.
- All electrical wiring must be completed in accordance with local, state and national codes and regulations and with the National Electric Code (ANSI/NFPA 70) or in Canada the Canadian Electric Code Part 1 CSA C.22.1.
- This equipment contains liquid and gaseous refrigerant under high pressure. **DO NOT USE ANY PORTION OF THE CHARGE FOR PURGING OR LEAK TESTING.** Installation or servicing should only be performed by qualified trained personnel thoroughly familiar with this type equipment.
- Fully annealed, refrigerant grade copper tubing should be used when installing the system. Refrigerant suction line tubing should be fully insulated.
- Installation of equipment may require brazing operations. Installer must comply with safety codes and wear appropriate safety equipment (safety glasses, work gloves, fire extinguisher, etc.) when performing brazing operations.
- Follow all precautions in the literature, on tags, and on labels provided with the equipment. Read and thoroughly understand the instructions provided with the equipment prior to performing the installation and operational checkout of the equipment.
- Refrigerant and electrical line should be routed through suitably waterproofed openings to prevent water from leaking into the structure.
- This unit is designed for outdoor installations only and should be positioned as shown on [page 3](#).

## AIR CONDITIONER INSTALLATION

### General Information

The \*SA(1,2)BD4M series air conditioner is designed only for outdoor rooftop or ground level installations. This unit has been tested for capacity and efficiency in accordance with AHRI Standards and will provide many years of safe and dependable comfort, providing it is properly installed and maintained. Abuse, improper use, and/or improper maintenance can shorten the life of the appliance and create unsafe hazards.

To achieve optimum performance and minimize equipment failure, it is recommended that periodic maintenance be performed on this unit. The ability to properly perform maintenance on this equipment requires certain mechanical skills and tools.

### Before You Install this Unit

- ✓ The cooling load of the area to be conditioned must be calculated and a system of the proper capacity selected. It is recommended that the area to be conditioned be completely insulated and vapor sealed.
- ✓ Check the electrical supply and verify the power supply is adequate for unit operation. The system must be wired and provided with circuit protection in accordance with local building codes. If there is any question concerning the power supply, contact the local power company.
- ✓ The indoor section (air handler, furnace, etc) should be installed before routing the refrigerant tubing. Refer to the indoor unit's installation instructions for installation details.
- ✓ All units are securely packed at the time of shipment and upon arrival should be carefully inspected for damage prior to installing the equipment at the job site. Verify coil fins are straight. If necessary, comb fins to remove flattened or bent fins. Claims for damage (apparent or concealed) should be filed immediately with the carrier.
- ✓ Please consult your dealer for maintenance information and availability of maintenance contracts. Please read all instructions before installing the unit.

### Locating the Air Conditioner

- Survey the job site to determine the best location for mounting the outdoor unit.
- The outdoor unit should be installed no closer than 18 inches from the outside walls of the facility and in an area free from overhead obstructions to ensure unrestricted airflow through the outdoor unit.
- Sufficient clearance for unobstructed airflow through the outdoor coil must be maintained in order to achieve rated performance. See [Figure 1](#) for minimum clearances to obstructions.
- Overhead obstructions ([Figure 1](#)), poorly ventilated areas, and areas subject to accumulation of debris should be avoided.
- Consideration should be given to availability of electric power, service access, noise, and shade.

### Packaging Removal

**NOTE:** To prevent damage to the tubing connections, carefully remove the carton and user's manual from the equipment. Discard the shipping carton.

### Ground Level

Ground level installations must be located according to local building codes or ordinances and these requirements:

- Clearances must be in accordance with those shown in [Figure 1](#).
- A suitable mounting pad ([Figure 1](#)) must be provided and separate from the building foundation. The pad must be level and strong enough to support the weight of the unit. The slab height must be a minimum of 2" (5 cm) above grade and with adequate drainage.

### Roof Mount

- The method of mounting should be designed so that it does not overload roof structures or transmit noise to the interior of the structure. The roof must be structurally capable of handling the weight of the unit.
- Full perimeter support is required under the unit. Support must be made of weather resistant materials and installed prior to unit installation.
- The support must be built to raise the unit 6" above the roof.

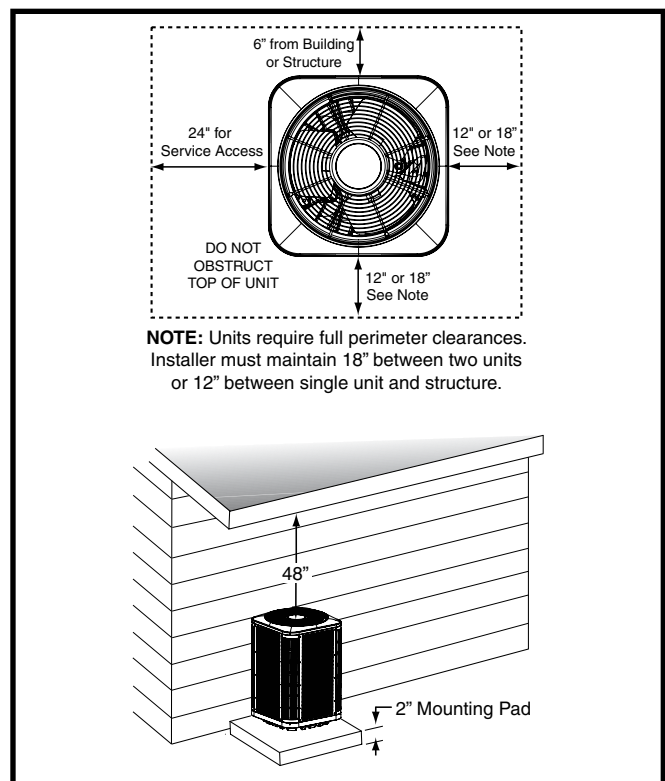

**Figure 1. Clearance Requirements**

---

 **CAUTION:**

---

**When servicing, cover or seal openings to minimize the exposure of the refrigerant system to air to prevent accumulation of moisture and other contaminants.**

---

After outdoor and indoor unit placement has been determined, route refrigerant tubing between the equipment in accordance with sound installation practices.

- When connecting refrigerant linesets together, it is recommended that dry nitrogen be flowing through the joints during brazing to prevent internal oxidation and scaling.
- Refrigerant tubing should be routed in a manner that minimizes the length of tubing and the number of bends in the tubing. If precise forming of refrigerant lines is required, a copper tubing bender is recommended. Avoid sharp bends and contact of the refrigerant lines with metal surfaces.
- Refrigerant tubing should be supported in a manner that the tubing will not vibrate or abrade during system operation.
- Tubing should be kept clean of foreign debris during installation.
- Every effort should be made by the installer to ensure that the field installed refrigerant containing components of the system have been installed in accordance with these instructions and sound installation practices to insure reliable system operation and longevity.
- The maximum recommended interconnecting refrigerant line lengths is 75 ft. and the vertical elevation difference between the indoor and outdoor sections should not exceed 20 ft.
- A filter dryer is provided with the unit and must be installed in the liquid line of the system. If the installation replaces a system with a filter dryer already present in the liquid line, the filter dryer must be replaced with the one supplied with the unit. The filter dryer must be installed in strict accordance with the manufacturer's installation instructions.
- Optional equipment such as liquid line solenoid valves, low ambient, etc., should be installed in strict accordance with the manufacturer's installation instructions.

 **WARNING:**

---

**To avoid risk of electrical shock, personal injury, or death, disconnect all electrical power to the unit before performing any maintenance or service. The unit may have more than one electrical supply.**

**Label all wires prior to disconnection when servicing the unit. Wiring errors can cause improper and dangerous operation.**

---

- All electrical connections must be in compliance with all applicable local codes and ordinances, and with the current revision of the National Electric Code (ANSI/NFPA 70).
- For Canadian installations the electrical connections and grounding shall comply with the current Canadian Electrical Code (CSA C22.1 and/or local codes).

**Pre-Electrical Checklist**

- ✓ Verify that the voltage, frequency, and phase of the supply source match the specifications on the unit rating plate.
- ✓ Verify that the service provided by the utility is sufficient to handle the additional load imposed by this equipment. Refer to the unit wiring label for proper voltage wiring.
- ✓ Verify factory wiring is in accordance with the unit wiring diagrams [Figure 5 \(page 9\)](#) and [Figure 6 \(page 10\)](#). Inspect for loose connections.

**Line Voltage**

- A wiring diagram is located on the inside cover of the electrical box of the outdoor unit. The installer should become familiar with the wiring diagram before making any electrical connections to the outdoor unit.
- An electrical disconnect must be located within sight of and readily accessible to the unit. This switch shall be capable of electrically de-energizing the outdoor unit.
- Line voltage to the unit should be supplied from a dedicated branch circuit containing the correct fuse or circuit breaker for the unit. Incoming field wiring and minimum size of electrical conductors and circuit protection must be in compliance with information listed on the outdoor unit data label. Any other wiring methods must be acceptable to authority having jurisdiction.
- The outdoor unit requires both power and control circuit electrical connections. Refer to the wiring diagram for identification and location of outdoor unit field wiring interfaces [Figure 5 \(page 9\)](#) and [Figure 6 \(page 10\)](#). Make all electrical connections in accordance with all applicable codes and ordinances.
- Overcurrent protection must be provided at the branch circuit distribution panel and sized as shown on the unit rating label and according to applicable local codes. See the unit rating plate for minimum circuit ampacity and maximum overcurrent protection limits.
- Provide power supply for the unit in accordance with the unit wiring diagram, and the unit rating plate. Connect the line-voltage leads to the terminals on the contactor inside the control compartment.
- Use only copper wire for the line voltage power supply to this unit in strict accordance of the NEC (ANSI/NFPA 70), applicable local codes, and the instructions provided with

the equipment. Use proper code agency listed conduit and a conduit connector for connecting the supply wires to the unit. Use of rain tight conduit is recommended.

- 208/230 Volt units are shipped from the factory wired for 230 volt operation. For 208V operation, remove the lead from the transformer terminal marked 240V and connect it to the terminal marked 208V.
- Optional equipment requiring connection to the power or control circuits must be wired in strict accordance of the NEC (ANSI/NFPA 70), applicable local codes, and the instructions provided with the equipment.

## Grounding

### **WARNING:**

**The unit cabinet must have an uninterrupted or unbroken electrical ground to minimize personal injury if an electrical fault should occur. Do not use gas piping as an electrical ground!**

This unit must be electrically grounded in accordance with local codes or, in the absence of local codes, with the National Electrical Code (ANSI/NFPA 70) or the CSA C22.1 Electrical Code. Use the grounding lug provided in the control box for grounding the unit.

### Comfort Alert™ Diagnostics Module (Select Models Only)

The Comfort Alert™ Diagnostics Module (Figure 2) is a breakthrough innovation that troubleshoots heat pump and air conditioning system failures and accurately detects the cause of electrical and system related failures without any sensors. The module installs easily in the electrical box of the outdoor unit near the compressor contactor. By monitoring and analyzing data from the Copeland scroll compressor and the thermostat demand, the module can accurately detect the cause of electrical and system related failures without any sensors. A flashing LED indicator communicates the ALERT code and a diagnostic key is also imprinted on the side of the module to quickly direct the technician to the root cause of a problem.

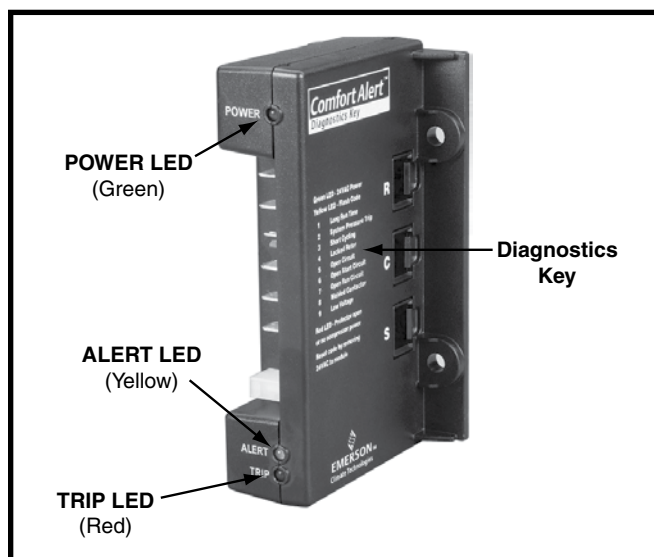

Figure 2. Comfort Alert™ Diagnostics Module

**NOTE:** This module does not provide safety protection! The Comfort Alert™ Diagnostics Module is a monitoring device and cannot control or shut down other devices.

### 24 VAC Power Wiring

The Comfort Alert™ module requires a constant nominal 24 VAC power supply. The module cannot be powered by the **C** terminal on a defrost board or other control board without experiencing nuisance alerts. **NOTE:** The wiring to the module's **R** & **C** terminals must be routed directly from the indoor unit or thermostat.

If the constant 24 VAC (**R** wire) is not present in the outdoor unit, use one of the spare wires in the thermostat cable to bring power to the module. Connect the other end of the spare wire to **R** at the indoor unit or thermostat.

### Thermostat Demand Wiring

The Comfort Alert™ module requires a thermostat demand signal to operate properly. The thermostat demand signal input (labeled **Y** on the module), should always be connected to the compressor contactor coil. **NOTE:** When the coil is energized, the demand signal input is 24 VAC. When the coil is not energized, the demand signal input should be less than 0.5 VAC.

#### NOTES:

- Factory installed modules have different thermostat demand signal wiring. Always follow manufacturer wiring instructions when replacing the module.
- After the thermostat demand signal is connected, verify that 24 VAC across Y & C when demand is present.

### Interpreting the Diagnostic LED's

When an abnormal system condition occurs, the Comfort Alert™ module displays the appropriate ALERT and/or TRIP LED will flash a number of times consecutively, pause and then repeat the process. To identify a Flash Code number, count the number of consecutive flashes.

Each time the module powers up, the last ALERT Flash Code that occurred prior to shut down is displayed for one minute. The module will continue to display the LED until the condition returns to normal or if 24 VAC power is removed from the module. See Table 1 (page 11) for flash code identification or Table 2 (page 12) for module wiring troubleshooting.

### LED Description

- POWER LED (Green): indicates voltage is present at the power connection of the module.
- ALERT LED (Yellow): communicates an abnormal system condition through a unique flash code. **NOTE:** The ALERT LED will flash consecutively, pause and then repeat the process. The number of consecutive flashes, referred to as the Flash Code, correlates to a particular abnormal condition. Detailed descriptions of these ALERT Flash Codes are listed in Table 1 (page 11) and Table 2 (page 12).
- TRIP LED (Red): indicates a demand signal is received from the thermostat, but current to the compressor is not detected by the module. The TRIP LED typically indicates if the compressor protector is open or the compressor has no power.

The scroll compressor's **R** (run), **C** (common), and **S** (start) wires are routed through the holes in the Comfort Alert™ module marked **R**, **C**, & **S**. **NOTE:** The common wire does not need to be routed through the module for it to operate.

### Thermostat Connections

- Thermostat connections should be made in accordance with the instructions supplied with the thermostat and the indoor equipment.
- The outdoor unit is designed to operate from a 24 VAC Class II control circuit. The control circuit wiring must comply with the current provisions of the NEC (ANSI/NFPA 70) and with applicable local codes having jurisdiction.
- The low voltage wires must be properly connected to the unit's low voltage terminal block.
- The thermostat should be mounted about 5 feet above the floor on an inside wall. DO NOT install the thermostat on an outside wall or any other location where its operation may be adversely affected by radiant heat from fireplaces, sunlight, or lighting fixtures, and convective heat from warm air registers or electrical appliances. Refer to the thermostat manufacturer's instruction sheet for detailed mounting and installation information.

## AIR CONDITIONER MAINTENANCE

### WARNING:

**To prevent electrical shock, personal injury, or death, disconnect all electrical power to the unit before performing any maintenance or service. The unit may have more than one electrical supply.**

Proper maintenance is important to achieve optimum performance from the air conditioner. The ability to properly perform maintenance on this equipment requires certain mechanical skills and tools. If you do not possess these skills, contact your dealer for maintenance. Consult your local dealer about the availability of maintenance contracts. Routine maintenance should include the following:

- Inspect and clean or replace air filters at the beginning of each heating and cooling season, or more frequently if required.
- Inspect the condensate drain and outdoor coil at the beginning of each cooling season. Remove any debris. Clean the outdoor coil and louvers as necessary using a mild detergent and water. Rinse thoroughly with water.
- Inspect the electrical connections for tightness at the beginning of each heating and cooling season. Service as necessary.

### CAUTION:

**The unit should never be operated without a filter in the return air system. Replace disposable filters with the same type and size.**

- Do not attempt to add additional oil to motors unequipped with oil tubes. The compressor is hermetically sealed at the factory and does not require lubrication.
- To access the internal components of the unit, refer to [Figure 3 \(page\) 6](#) for panel removal and [Figure 4 \(page\) 6](#) for panel installation.

### Panel Removal

1. Remove screws securing the panel.
2. Slide the panel up towards the top pan in order to clear the bottom flange from the base pan. See [Figure 3](#).
3. Swing the bottom of the panel out and pull the panel down to remove it from the unit.

### Panel Installation

1. Insert the top corners of side panel flanges into the corner post channels as shown in [Detail A](#) in [Figure 4](#).
2. Slide the panel up into the top pan. (You may need to push on the center of the panel at the top in order to clear the top pan edge).
3. Swing the panel in and push down until the panel is resting on the top edge of the base pan wall as shown in [Detail B](#).
4. Install screws into the panel to secure it to the unit.

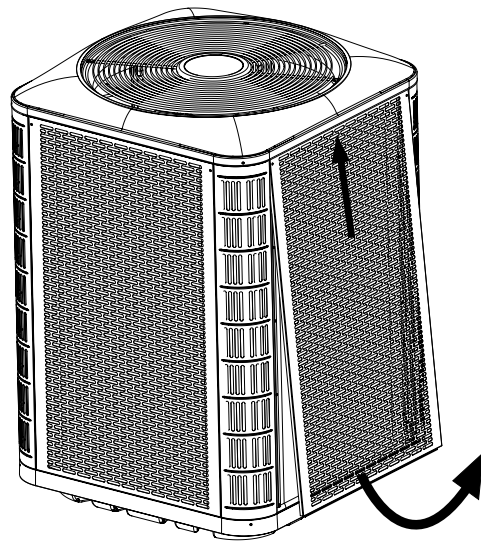

Figure 3. Panel Removal

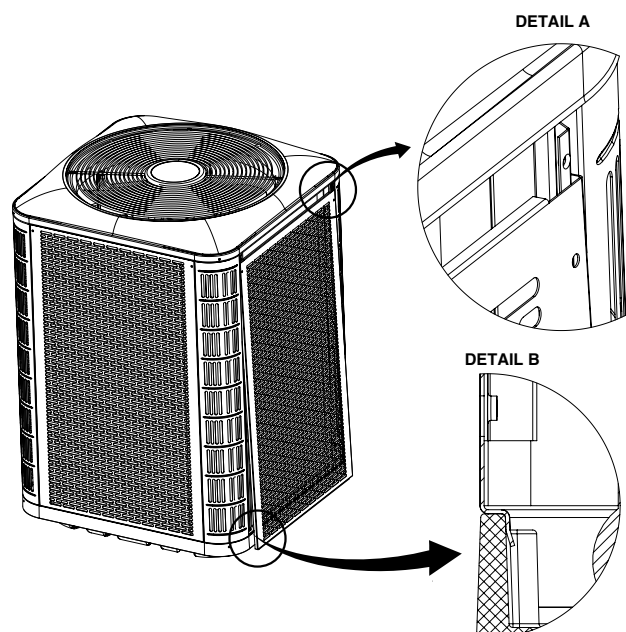

Figure 4. Panel Installation

## START UP & ADJUSTMENTS

### Pre-Start Check List

- √ Verify the indoor unit is level and allows proper condensate drainage.
- √ Verify the outdoor coil and top of the unit are free from obstructions and debris, and all equipment access/control panels are in place.
- √ Verify air filters are cleaned and properly installed.
- √ Verify duct work is sealed to prevent air leakage.
- √ Verify line voltage power leads are securely connected and the unit is properly grounded.
- √ Verify low voltage wires are securely connected to the correct leads on the low voltage terminal strip.
- √ Verify power supply branch circuit overcurrent protection is sized properly.
- √ Verify the thermostat is wired correctly.

### Start-Up Procedures

The thermostat's function mode should be set to OFF and the fan mode should be set to AUTO. Close all electrical disconnects to energize the system.

#### Air Circulation - Indoor Blower

1. Set the thermostat system mode on OFF and the fan mode to ON.
2. Verify the blower runs continuously. Check the air delivery at the supply registers and adjust register openings for balanced air distribution. If insufficient air is detected, examine ductwork for leaks or obstructions.
3. Set the thermostat fan mode to AUTO and verify the blower stops running.

#### System Cooling

1. Set the thermostat's system mode to COOL and the fan mode to AUTO. Gradually lower the thermostat temperature setpoint below room temperature and verify the outdoor unit and indoor blower energize.
2. Verify blower wheel is spinning in direction indicated by arrow. Feel the air being circulated by the indoor blower and verify that it is cooler than ambient temperature. Listen for any unusual noises. If unusual sounds occur, determine the source of the noise and correct as necessary.
3. Verify HI and LO refrigerant pressures.
4. Allow the system to operate for several minutes and then set the temperature selector above room temperature. Verify the fan and compressor cycle off with the thermostat.  
**NOTE:** The blower should also stop unless fan mode is set to the ON position.

#### System Heating (optional)

1. Set the thermostat's system mode to HEAT and the temperature mode above room temperature.
2. Verify the optional heating equipment (furnace or electric heat) and indoor blower energize. Feel the air being circulated by the indoor blower and verify that it is warmer than ambient temperature. Listen for any unusual noises. If unusual sounds occur, determine the source of the noise and correct as necessary.

## REFRIGERANT CHARGING

---

### **WARNING:**

---

**\*SA(1,2)BD4M Split System Air Conditioners are shipped charged with R410A refrigerant and ready for installation. If repairs make it necessary for evacuation and charging, it should only be attempted by qualified trained personnel thoroughly familiar with this equipment. Under no circumstances should the owner attempt to install and/or service this equipment. Failure to comply with this warning could result in property damage, personal injury, or death.**

---

After refrigerant line connections are completed, it is required that you leak check and evacuate the indoor section and all line connections (using proper methods) before finalizing the full system refrigerant charge.

- \*SA(1,2)BD4M outdoor units with non-AHRI listed indoor coils are not recommended. Deviations from rated airflows or non-listed combinations may require modification to the expansion device and refrigerant charging procedures for proper and efficient system operation.
- The refrigerant charge can be checked and adjusted through the service ports provided external to the outdoor unit. Use only gage line sets which have a "Schrader" depression device present to actuate the valve.
- A high-pressure switch is factory-installed and located in the liquid line internal to the outdoor unit. The switch is designed to protect the system when very high pressures occur during abnormal conditions. Under normal conditions, the switch is closed. If the liquid pressure rises above 575 psig, then the switch will open and de-energize the outdoor unit. The switch will close again once the liquid pressure decreases to 460 psig. Please note that the switch interrupts the thermostat inputs to the unit. Thus, when the switch opens and then closes, there may be a 5 minute short cycling delay before the outdoor unit will energize.
- A low-pressure switch (Select Models) is factory-installed and located in the suction line internal to the outdoor unit. The switch is designed to protect the compressor from a loss of charge. Under normal conditions, the switch is closed. If the suction pressure falls below 5 psig, then the switch will open and de-energize the outdoor unit. The switch will close again once the suction pressure increases above 20 psig. Please note that the switch interrupts the thermostat inputs to the unit. When the switch opens and then closes, there will be a 5 minute short cycling delay before the outdoor unit will energize.

## Charging the Unit in AC mode

If the outdoor temperature is 65 degrees F or higher:

After completing the refrigerant line connections, leak checking the system, and evacuating the indoor section and all line connections (using proper methods), perform the following steps:

1. Determine the recommended charge addition (if applicable) for the system being installed. This information is in the unit's QRD (Quick Reference Data sheet).
2. Calculate the amount of additional refrigerant needed for the line set length of the actual installation. This information is on the first page of the unit's QRD (Quick Reference Data sheet).
3. Weigh in the additional charge amounts determined by step 1 and 2 above.
4. Adjust the charge to match the superheat (for fixed orifice systems) or subcooling (for TXV systems). There are three different resources for doing this:
  - a.) The [chargecalculator.com](http://chargecalculator.com) website. This will walk you through the charging process step by step.
  - b.) The charging tables on the inside of the outdoor unit's electrical box cover panel. These tables provide superheat targets for fixed orifice systems and subcooling targets for TXV systems. The system should be charged so that the measured superheat/subcooling are within 1 degree F of the target listed in the table.

### For fixed orifice systems:

- If your measured superheat at the suction valve is **LESS THAN** the recommended superheat value in the table then **REMOVE** refrigerant.
- If your measured superheat at the suction valve is **GREATER THAN** the recommended superheat value in the table then **ADD** refrigerant.

### For TXV systems:

- If your measured subcooling at the liquid valve is **LESS THAN** the recommended subcooling value in the table then **ADD** refrigerant.
  - If your measured subcooling at the liquid valve is **GREATER THAN** the recommended subcooling value in the table then **REMOVE** refrigerant.
- c.) The charging tables in the Supplemental Charging Information, can be found online in the literature library. The tables can also be accessed by scanning the QR code on the unit's electrical panel. The pressures listed in these tables are for reference only and are to be used in troubleshooting a system. **The system should be charged to match the superheat or subcooling targets as previously noted and not to match the system pressures.** Follow the same procedure described in 4b above.

If the outdoor temperature is below 65 degrees F:

After completing the refrigerant line connections, leak checking the system, and evacuating the indoor section and all line connections (using proper methods), perform the following steps:

1. Determine the recommended charge addition (if applicable) for the system being installed. This information is in the unit's QRD (Quick Reference Data sheet).
2. Calculate the amount of additional refrigerant needed for the line set length of the actual installation. This information is on the first page of the unit's QRD (Quick Reference Data sheet).
3. Weigh in the additional charge amounts determined by step 1 and 2 above.
4. Return to the system when the outdoor temperature is 65 degrees F or higher and follow the steps defined in step 4 of the "If the outdoor temperature is 65 degrees F or higher" section above.



# WIRING DIAGRAM

## Split System Air Conditioner (Outdoor Section)

## Single Phase

**NOTES:**

1. Disconnect all power before servicing.
2. For supply connections use copper conductors only.
3. Not suitable on systems that exceed 150 volts to ground.
4. For replacement wires use conductors suitable for 105 deg C.
5. For ampacities and overcurrent protection, see unit rating plate.
6. Connect to 24 vac/40ca/class 2 circuit. See furnace/airhandler installation instructions for control circuit and optional relay/transformer kits.
7. Anti-Short Cycle Timer (ASCT) may or may not be installed in the unit. If desired, ASCT is factory installed on select models only or may be field installed as shown using manufacturer's approved kit. If not present, connect Yellow and Black wires per Note 6.

1. Couper le courant avant de faire letretien.
2. Employez uniquement des conducteurs en cuivre.
3. Ne convient pas aux installations de plus de 150 volt a la terre.

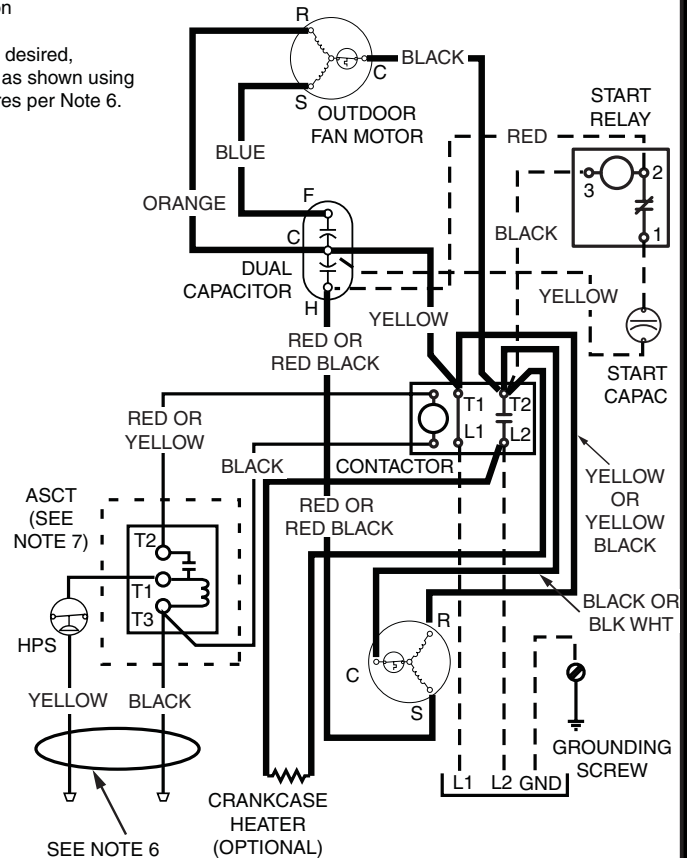
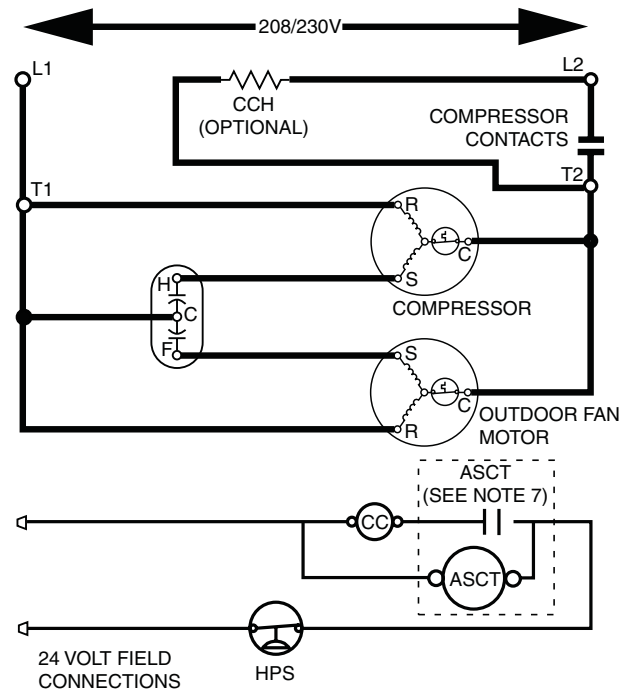

**LEGEND:**

CC - Contactor Coil  
 CCH - Crankcase Heater  
 HPS - High Pressure Switch

FIELD WIRING	---
LOW VOLTAGE	— — —
HIGH VOLTAGE	—————



**710388B**  
 (Replaces 710388A)

0109

Figure 5. Wiring Diagram for \*SA(1,2)BD4M1SN (1.5, 2, 2.5, 3, 3.5, 4, & 5 Ton Units)

# WIRING DIAGRAM

## Split System Air Conditioner(Outdoor Section)

## Single Phase

### NOTES:

1. Disconnect power before servicing.
2. For supply connections use copper conductors only.
3. Not suitable on systems that exceed 150 volts to ground.
4. For replacement wires use conductors suitable for 105 deg C.
5. For ampacities and overcurrent protection, see unit rating plate.
6. Connect to 24 vac/40ca/class 2 circuit. See furnace/airhandler installation instructions for control circuit and optional relay/transformer kits.
7. Anti-Short Cycle Timer (ASCT) may or may not be installed in the unit. If desired, ASCT is factory installed on select models only or may be field installed as shown using manufacturer's approved kit. If not present, connect Yellow and Black wires per Note 6.
8. DO NOT use a Hard Start Kit on a model with a PTCR installed.

1. Couper le courant avant de faire letrretien.
2. Employez uniquement des conducteurs en cuivre.
3. Ne convient pas aux installations de plus de 150 volt a la terre.

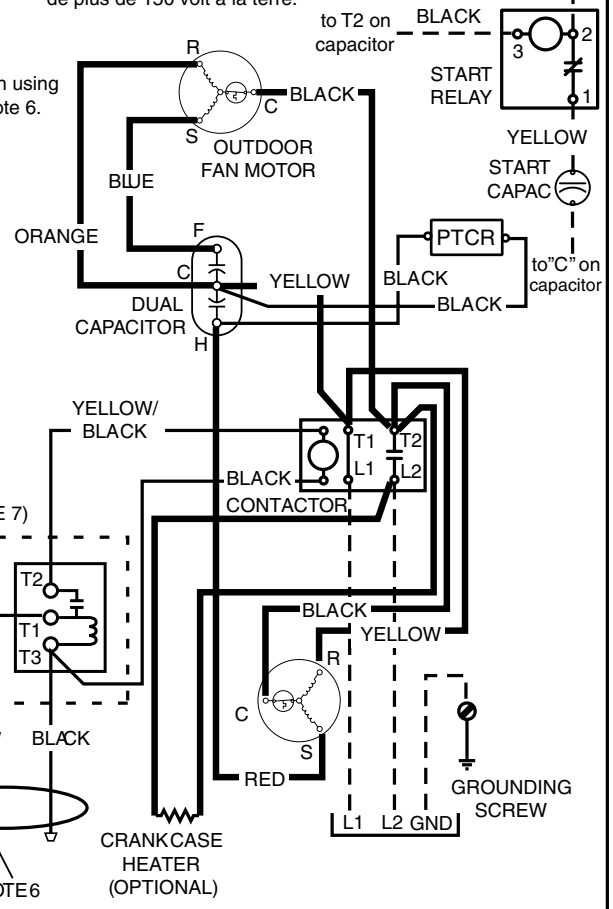
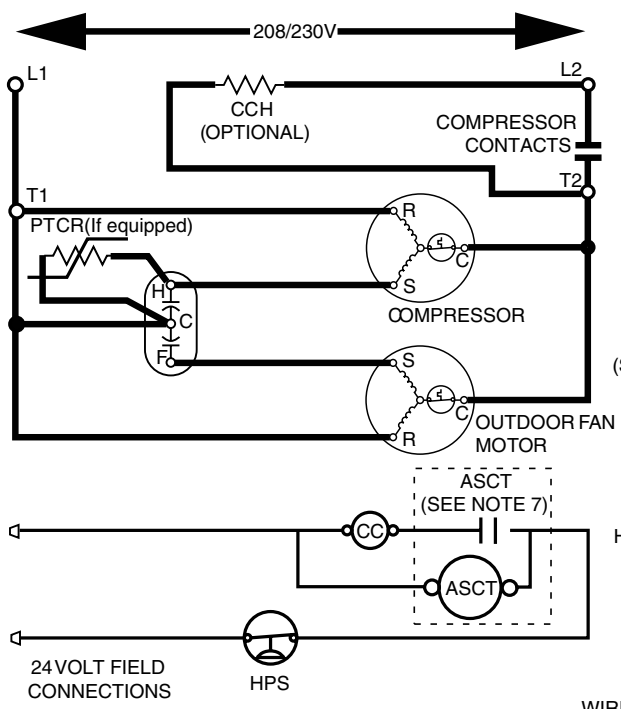

**LEGEND:**

CC - Contactor Coil  
 CCH - Cranks case Heater  
 HPS - High Pressure Switch

FIELD WIRING - - - - -  
 LOW VOLTAGE - - - - -  
 HIGH VOLTAGE - - - - -



7110050

Figure 6. Wiring Diagram for \*SA(1,2)BD4M1RN (1.5, 2, 2.5, & 3 Ton Units)

Status LED	Status LED Description	Status LED Troubleshooting Information
POWER (Green LED)	Module has power	Supply voltage is present at module terminals
TRIP (Red LED)	Thermostat demand signal Y is present, but compressor is not running	<ul style="list-style-type: none"> <li>• Compressor protector is open</li> <li>• Check for high head pressure</li> <li>• Check compressor supply voltage</li> <li>• Outdoor unit power disconnect is open</li> <li>• Compressor circuit breaker or fuse(s) is open</li> <li>• Broken wire or connector is not making contact</li> <li>• Low pressure switch open if present in system</li> <li>• Compressor contactor has failed open</li> </ul>
ALERT Flash Code 1 (Yellow LED)	Long Run Time Compressor is running extremely long run cycles	<ul style="list-style-type: none"> <li>• Low refrigerant charge</li> <li>• Evaporator blower is not running <ul style="list-style-type: none"> <li>— Check blower relay coil and contacts</li> <li>— Check blower motor capacitor</li> <li>— Check blower motor for failure or blockage</li> <li>— Check evaporator blower wiring and connectors</li> <li>— Check indoor blower control board</li> <li>— Check thermostat wiring for open circuit</li> </ul> </li> <li>• Evaporator coil is frozen <ul style="list-style-type: none"> <li>— Check for low suction pressure</li> <li>— Check for excessively low thermostat setting</li> <li>— Check evaporator airflow (coil blockages or return airfilter)</li> <li>— Check ductwork or registers for blockage</li> </ul> </li> <li>• Faulty metering device <ul style="list-style-type: none"> <li>— Check TXV bulb installation (size, location and contact)</li> <li>— Check if TXV/fixed orifice is stuck closed or defective</li> </ul> </li> <li>• Condenser coil is dirty</li> <li>• Liquid line restriction (filter drier blocked if present in system)</li> <li>• Thermostat is malfunctioning <ul style="list-style-type: none"> <li>— Solenoid plug not connected</li> <li>— Y2 not wired at Comfort Alert</li> <li>— Check thermostat sub-base or wiring for short circuit</li> <li>— Check thermostat installation (location, level)</li> </ul> </li> <li>• Comfort Alert failure</li> </ul>
ALERT Flash Code 2 (Yellow LED)	System Pressure Trip	<ul style="list-style-type: none"> <li>• High head pressure <ul style="list-style-type: none"> <li>— Check high pressure switch if present in system</li> <li>— Check if system is overcharged with refrigerant</li> <li>— Check for non-condensable in system</li> </ul> </li> </ul>
	Discharge or suction	<ul style="list-style-type: none"> <li>• Condenser coil poor air circulation (dirty, blocked, damaged)</li> </ul>
	Pressure out of limits	<ul style="list-style-type: none"> <li>• Condenser fan is not running <ul style="list-style-type: none"> <li>— Check fan capacitor</li> <li>— Check fan wiring and connectors</li> <li>— Check fan motor for failure or blockage</li> </ul> </li> </ul>
	Compressor overloaded	<ul style="list-style-type: none"> <li>• Return air duct has substantial leakage</li> <li>• If low pressure switch present in system, check Flash Code 1 information</li> </ul>
ALERT Flash Code 3 (Yellow LED)	Short Cycling / Compressor is running only briefly	<ul style="list-style-type: none"> <li>• Thermostat demand signal is intermittent</li> <li>• Low line voltage (contact utility if voltage at disconnect is low)</li> <li>• Excessive liquid refrigerant in compressor</li> <li>• Compressor bearings are seized</li> </ul>
ALERT Flash Code 4 (Yellow LED)	Locked Rotor	<ul style="list-style-type: none"> <li>• Run capacitor has failed</li> <li>• Low line voltage (contact utility if voltage at disconnect is low)</li> <li>• Check wiring connections</li> <li>• Excessive liquid refrigerant in compressor</li> <li>• Compressor bearings are seized</li> <li>• Measure compressor oil level</li> </ul>
ALERT Flash Code 5 (Yellow LED)	Open Circuit	<ul style="list-style-type: none"> <li>• Outdoor unit power disconnect is open</li> <li>• Compressor circuit breaker or fuse(s) is open</li> <li>• Compressor contactor has failed open <ul style="list-style-type: none"> <li>— Check compressor contactor wiring and connectors</li> <li>— Check for compressor contactor failure (burned, pitted or open)</li> <li>— Check wiring and connectors between supply and compressor</li> <li>— Check for low pilot voltage at compressor contactor coil</li> <li>— High pressure switch is open and requires manual reset</li> </ul> </li> <li>• Open circuit in compressor supply wiring or connections</li> <li>• Unusually long compressor protector reset time due to extreme ambient temperature</li> <li>• Compressor windings are damaged <ul style="list-style-type: none"> <li>— Check compressor motor winding resistance</li> </ul> </li> </ul>

**Table 1. Comfort Alert LED Diagnostics**

Status LED	Status LED Description	Status LED Troubleshooting Information
ALERT Flash Code 6 (Yellow LED)	Open Start Circuit Current only in run circuit	<ul style="list-style-type: none"> <li>Run capacitor has failed</li> <li>Open circuit in compressor start wiring or connections <ul style="list-style-type: none"> <li>Check wiring and connectors between supply and the compressor <b>S</b> terminal</li> </ul> </li> <li>Compressor start winding is damaged <ul style="list-style-type: none"> <li>Check compressor motor winding resistance</li> </ul> </li> </ul>
ALERT Flash Code 7 (Yellow LED)	Open run circuit Current only in start circuit	<ul style="list-style-type: none"> <li>Open circuit in compressor run wiring or connections <ul style="list-style-type: none"> <li>Check wiring and connectors between supply and the compressor <b>R</b> terminal</li> </ul> </li> <li>Compressor run winding is damaged <ul style="list-style-type: none"> <li>Check compressor motor winding resistance</li> </ul> </li> </ul>
ALERT Flash Code 8 (Yellow LED)	Welded Contactor Compressor always runs	<ul style="list-style-type: none"> <li>Compressor contactor has failed closed</li> <li>Thermostat demand signal not connected to module</li> </ul>
ALERT Flash Code 9 (Yellow LED)	Low Voltage Control circuit < 17VAC	<ul style="list-style-type: none"> <li>Control circuit transformer is overloaded</li> <li>Low line voltage (contact utility if voltage at disconnect is low)</li> <li>Check wiring connections</li> </ul>

\* Flash code number corresponds to a number of LED flashes, followed by a pause and then repeated. Trip and alert LED's flashing at same time means control circuit voltage is too low for operation.

**Table 10. LED Diagnostics - Continued**

Miswired Module Indication	Recommended Troubleshooting Action
Green LED is not on, module does not power up	<ul style="list-style-type: none"> <li>Determine if both <b>R</b> &amp; <b>C</b> module terminals are connected.</li> <li>Verify voltage is present at module's <b>R</b> &amp; <b>C</b> terminals.</li> </ul>
Green LED intermittent, module powers up only when compressor runs	<ul style="list-style-type: none"> <li>Determine if <b>R</b> &amp; <b>Y</b> terminals are wired in reverse.</li> <li>Verify modules <b>R</b> &amp; <b>C</b> terminals have a constant source.</li> </ul>
Trip LED is on, but system and compressor check OK	<ul style="list-style-type: none"> <li>Verify <b>Y</b> terminal is connected to 24VAC at contactor coil.</li> <li>Verify voltage at contactor coil falls below 0.5VAC when off.</li> <li>Verify 24VAC is present across <b>Y</b> &amp; <b>C</b> when thermostat demand signal is preset. If not, <b>R</b> &amp; <b>C</b> are reversed wired.</li> </ul>
TRIP LED & ALERT LED flashing together	<ul style="list-style-type: none"> <li>Verify <b>R</b> &amp; <b>C</b> terminals are supplied with 19 - 28VAC.</li> </ul>
ALERT Flash CODE 3 displayed incorrectly (Compressor short cycling)	<ul style="list-style-type: none"> <li>Verify <b>Y</b> terminal is connected to 24VAC at contactor coil.</li> <li>Verify voltage at contactor coil falls below 0.5VAC when off.</li> </ul>
ALERT Flash Code 5, 6, or 7 displayed incorrectly (Open Circuit, Open Start Circuit or Open Run Circuit)	<ul style="list-style-type: none"> <li>Verify the compressor run and start wires are routed through the module's current sensing holes.</li> <li>Verify the <b>Y</b> terminal is connected to 24VAC at contactor coil.</li> <li>Verify voltage at contactor coil falls below 0.5VAC when off.</li> </ul>
ALERT Flash Code 6 (Open Start Circuit) displayed for Code 7 (Open Run Circuit) or vice-versa	<ul style="list-style-type: none"> <li>Verify the compressor run and start wires are routed through the correct module sensing holes.</li> </ul>
ALERT Flash Code 8 displayed incorrectly (Welded Contactor)	<ul style="list-style-type: none"> <li>Determine if module's <b>Y</b> terminal is connected.</li> <li>Verify <b>Y</b> terminal is connected to 24VAC at contactor coil.</li> <li>Verify 24VAC is present across <b>Y</b> &amp; <b>C</b> when thermostat demand signal is present. If not, <b>R</b> &amp; <b>C</b> are reversed wired.</li> <li>Verify voltage at contactor coil falls below 0.5VAC when off.</li> <li>Review Thermostat Demand Wiring (page 10) for <b>Y</b> &amp; <b>C</b> wiring.</li> </ul>

**Table 2. Module Wiring Troubleshooting**







## INSTALLATION CHECKLIST

<b>INSTALLATION ADDRESS:</b>		
CITY:	STATE:	
UNIT MODEL #:		
UNIT SERIAL #:		
<b>INSTALLER NAME:</b>		
CITY:	STATE:	
Unit Installed Minimum clearances per <a href="#">Figure 1 (page) 3?</a>	YES	NO
Has the owner's information been reviewed with the customer?	YES	NO
Has the Literature Package been left with the unit?	YES	NO

REFRIGERATION SYSTEM		
Was unit given 24 hr warm up period for crankcase heaters?	YES	NO
Stage-1 Liquid Pressure (high side):		
Stage-1 Suction Pressure (low side):		

ELECTRICAL SYSTEM		
Electrical connections tight?	YES	NO
Line voltage polarity correct?	YES	NO
Rated Voltage:		
Has the thermostat been calibrated?	YES	NO
Is the thermostat level?	YES	NO
Is the heat anticipator setting correct? (If Applicable)	YES	NO

### REPLACEMENT PARTS

Replacement parts are available through your distributor. Please have the complete model and serial number of the unit when ordering replacement parts.

#### ELECTRICAL:

- |                   |                            |
|-------------------|----------------------------|
| Capacitors        | Temperature Limit Switches |
| Compressors       | Thermostats                |
| Contactors        | Time Delay Relays          |
| Pressure Switches | Transformers               |
| Relays            |                            |

#### MOTORS:

- Blower Motor
- Fan Motor

#### COMPONENTS:

- Blower Assembly
- Cabinet Panels
- Expansion Valves
- Fan Grille
- Filter/Driers

