

Counterflow Gas or Oil Heating Appliance

OWNER'S MANUAL & INSTALLATION INSTRUCTIONS

**CMF80-PG Convertible (65, 75, and 90 KBTU/H Inputs),
CMF 100-PG (90 KBTU/H Input)
CMF80-PO Convertible (65, 75, and 90 KBTU/H Inputs),
CMF 100-PO (90 KBTU/H Input)**

Read all instructions carefully before beginning the installation. Read all labels and tags on the furnace carefully and follow all precautions outlined on those labels and tags.

FOR YOUR SAFETY

Do not store or use gasoline or other flammable vapors and liquids in the vicinity of this or any other appliance.

WARNING:

Improper installation, alteration, service or maintenance can cause injury or property damage. Refer to this manual for assistance or consult a qualified installer, service agency, or the gas supplier for additional information.

FOR YOUR SAFETY WHAT TO DO IF YOU SMELL GAS

- Do not try to light any appliance.
- Do not touch any electric switch; do not use any phone in your building.
- Immediately call your gas supplier from a neighbor's phone. Follow the gas supplier's instructions.
- If you cannot reach your gas supplier, call the fire department.

| Rated BTUH | CFM-PG 80 CONV. | CFM-PO 80 CONV. | CFM-PG 100 | CFM-PO 100 |
|------------|--------------------|--------------------|---------------|---------------|
| Input | 75,000 | 75,000 | 90,000 | 90,000 |
| Output | 56,000 | 60,000 | 68,000 | 72,000 |

GENERAL

CMF furnaces are high quality, direct vent furnaces used for manufactured housing, recreational vehicle, and residential applications. These furnaces are offered in either power gas (designated by PG) or power oil (designated by PO) models. The power gas models are designed for operation with either natural or propane (LP) gas.

The CMF series is convertible from power oil to power gas, and vice versa. Furthermore, the firing rate of the CMF80 Convertible Series can be changed using a certified NORDYNE conversion kit field-installed by a qualified service technician. Refer to the "Firing Rate Conversion" section later in these instructions for more information on the firing rate change.

These furnaces are certified to the UL307 standards (UL 307A for oil models; UL 307B for gas models), and can be installed in a variety of applications, as shown in Table 1. This furnace is not to be used for temporary heating of buildings or structures under construction.

WARNING:

This furnace must be installed by a qualified installing agency and in accordance with applicable local codes and ordinances that govern this type of equipment. Failure to properly install the furnace, base assembly, and venting system as described herein may damage the equipment and/or the home, can create a fire or asphyxiation hazard, violates U.S. listing requirements, and will void the warranty. This furnace is NOT approved for installation with split system air conditioning. Use a NORDYNE packaged air conditioning system.

WARNING:

Do not use this appliance if any part has been submerged under water. Immediately call a qualified service technician to inspect the appliance and to replace any part of the control system and any gas control that has been submerged under water.

INSTALLATION REQUIREMENTS

Equipment Check

All units are securely packaged at the time of shipment and should be carefully inspected upon arrival for damage. Claims for damages (apparent or concealed), shortage in shipment, or nondelivery should be filed immediately against the carrier by the consignee. The carrier is responsible for making prompt inspection of damage and for a thorough investigation of each claim. The manufacturer will not accept claims for transportation damage.

Requirements and Codes:

Installer shall be familiar with and comply with all codes and regulations and applicable to the installation of these heating appliances and related equipment.

All manufactured housing installations must conform with these instructions, all applicable local codes, ANSI Z223.1/NFPA 54 (National Fuel Gas Code), ANSI/NFPA 31 (Installation of Oil Burning Equipment), ANSI/NFPA 70 (National Electrical Code), the Manufactured Home Construction and Safety Standard, Title 24 CFR, part 3280, or when this standard is not applicable, the standard for Manufactured Home Installations (Manufactured Home Sites, Communities, and Set-ups), ANSI 225.1.

All residential installations (Refer to Table 1) must conform with these instructions, all applicable local building codes, ANSI Z223.1/NFPA 54 (National Fuel Gas Code), ANSI/NFPA 31 (Installation of Oil-Burning Equipment), ANSI/NFPA70 (National Electrical Code), and NFPA 211 (Chimneys, Fireplaces, Vents, and Solid Fuel-Burning Appliances).

The National Fuel Gas Code is available by writing:

American National Standards Institute, Inc.
1430 Broadway
New York, NY 10018

NFPA publications are available by writing:

National Fire Protection Association
Batterymarch Park
Quincy, ME 02269

Combustion Air and Ventilation Requirements

Provisions for adequate combustion air and ventilation air must be in accordance with the ANSI Z223.1/NFPA 54, (National Fuel Gas Code), ANSI/NFPA 31 (Installation of Oil Burning Equipment), and all applicable local codes.

Depending upon the type of installation (See Table 1), the CMF furnace can draw the combustion air either from outside the home (direct vent) or from the space being conditioned. A direct vent system is one in which the flue products are exhausted to and the combustion air is drawn from outside the house. A direct vent system can also be referred to as a sealed combustion system.

For direct vent applications either the combustion air duct provided with the MA Series base kit or the direct vent kit can be used. The direct vent kit must be ordered separately. Only for a special CB-200A cottage base installation can the CMF draw the combustion air from the conditioned space. The CB-200A cottage base kit must be ordered separately. Refer to the replacement parts listing provided with the furnace to order the direct vent kit or the cottage base kit. Follow the instructions provided with the kits for proper installation.

| Type of Installation | Ducted Application | Direct Vent System Required | Furnace Base Used | Flue Products Exhausted By |
|--|--------------------|-----------------------------|---------------------------------|--|
| Manufactured Housing or Recreational Vehicle | Yes | Yes | MA-100 or MA-200 Universal Base | NORDYNE SRJ Roofjack Only |
| Residential [†] | Yes | Yes | MA-100 or MA-200 Universal Base | NORDYNE SRJ Roofjack or an Existing Chimney* |
| Residential [†] | Yes | Yes | CB-200A Cottage Base | NORDYNE SRJ Roofjack or an Existing Chimney* |
| Residential [†] | No | No | CB-200A Cottage Base | NORDYNE SRJ Roofjack or an Existing Chimney* |

[†]Residential is only defined as a single-story non-manufactured housing installation.

*Refer to the "Venting Requirements" section later in these instructions for more details on properly venting this appliance through an existing chimney.

Table 1

When unsure about combustion air supply availability, a direct vent system should be used. For small rooms, confined spaces, tight construction or similar situations in which the combustion air requirements of the furnace might not be met, a direct vent system must be used. The air openings in the door of the unit and the warm air registers from the ductwork or base must not be restricted.

Combustion air must not be drawn from a contaminated atmosphere. Excessive exposure to contaminated combustion air will result in safety and performance related problems. Some examples of chemical contaminants are chlorine, fluorine, and sulfur, which can be found in a wide variety of some common commercial and household products.

The installation of the furnace must allow for an adequate supply of combustion air. The combustion air opening of the furnace must be designed and located to prevent blockage by snow.

When drawing the combustion air from underneath the home, ensure that a vent or duct of at least 18 square inches of free area is provided from outside. Check to ensure that the combustion air opening is unobstructed. When using the combustion air duct, ensure that it extends through the floor. When using the direct vent kit, the combustion air opening must be located in the same pressure zone as the flue exit of the roof jack or chimney. Refer to the instructions provided with the direct vent kit for more information.

Venting Requirements — Manufactured Housing Installations

For all manufactured housing applications, the CMF furnace must be vented using the SRJ series roofjack. The instructions for selecting the proper roofjack for your installation are detailed later in these instructions.

Venting Requirements — Residential Installations

WARNING:

This furnace is not to be connected to a chimney flue serving a separate appliance designed to burn solid fuel.

For residential applications (Refer to Table 1), the CMF furnace may be vented through the SRJ series roofjack or through an existing chimney. If the SRJ roofjack is to be used, then the instructions for selecting the proper roofjack for your installation are detailed later in these instructions. If venting through an existing chimney, then the venting system used must be in accordance with these instructions, all applicable local building codes, ANSI Z223.1/NFPA 54 (National Fuel Gas Code), ANSI/NFPA 31 (Installation

of Oil-Burning Equipment), and NFPA 211 (Chimneys, Fireplaces, Vents, and Solid Fuel-Burning Appliances).

WARNING:

When venting through a chimney, check the chimney for soot, leaks, obstructions, and proper installation.

The materials used to construct the venting system must be capable of withstanding exposure to temperatures of at least 700 degrees

F. The existing chimney servicing this furnace must be vertical. Horizontal distances to an existing chimney must be as short as possible, and the connecting pipe must slope upward to the chimney at not less than a 45 degree angle. The total length of the sloping pipe must not exceed 6 feet. The venting system must have no obstructions or sharp bends where soot and other foreign matter can accumulate.

If an inspection determines that the chimney is obstructed, the chimney must be cleaned. Furthermore, the connecting flue pipe must be cleaned or replaced.

For ONLY a CMF power oil furnace installation vented into an existing chimney, a barometric damper can be installed at the vent connection of the furnace to regulate the draft. The barometric damper must be properly installed per the manufacturer's instructions. Refer to all applicable codes to determine whether or not a barometric damper can be used for your CMF power oil furnace installation. The barometric damper used must be installed such that air from the conditioned space can only enter the flue passageway. Do not use a double acting barometric damper. All flue pipe joints should be fastened with sheet metal screws for rigidity.

The chimney height, required draft, and number of appliances served by the chimney must be in accordance with all applicable codes. To prevent down draft, the chimney should extend at least two feet above the peak of the roof.

It is recommended that the furnace flue serve no other appliances. When the chimney serves only the furnace, the flue area must be sized according to all applicable codes. The minimum internal area of the flue must be equal to at least the area of the furnace flue exit.

When two or more appliances must vent through a common flue, the area of the common flue should be sized in accordance with all applicable codes.

When an existing furnace is removed or replaced in a venting system, then the venting system may not be properly sized to vent the attached appliances. The venting system must be checked to ensure proper venting.

Improperly sized venting systems can result in the formation of condensate, leakage, spillage, et cetera. Refer to the ANSI Z223.1/NFPA 54, (National Fuel Gas Code), and ANSI/NFPA 31(Installation of Oil Burning Equipment) for correcting any improperly operating venting system.

The following steps shall be followed with each appliance connected to the venting system placed in operation, while any other appliances connected to the venting system are not in operation:

- a) Seal any unused openings in the venting system.
- b) Inspect the venting system for proper size and horizontal pitch, as required in the ANSI Z223.1/NFPA 54, (National Fuel Gas Code) and ANSI/NFPA 31 (Installation of Oil Burning Equipment), and these instructions. Determine that there is no blockage or restriction, leakage, corrosion or other deficiencies which could cause an unsafe condition.
- c) In so far as is practical, close all building doors and windows and all doors between the space in which the appliance(s) connected to the venting system are located and other spaces of the building. Turn on clothes dryers and any appliance not connected to the venting system. Turn on any exhaust fans, such as range hoods and bathroom exhausts, so they shall operate at maximum speed. Do not operate a summer exhaust fan. Close fireplace dampers.
- d) Follow the lighting instructions. Place the appliance being inspected in operation. Adjust thermostat so appliance shall operate continuously.
- e) Test for draft hood equipped appliance spillage at the draft hood relief opening after 5 minutes of main burner operation. Use the flame of a match or candle.
- f) After it has been determined that each appliance connected to the venting system properly vents when tested as out- lined above, return doors, windows, exhaust fans, fireplace dampers and any other gas burning appliance to their previous conditions of use.
- g) If improper venting is observed during any of the above tests, the venting system must be corrected.

INSTALLER INFORMATION

IMPORTANT SAFETY INFORMATION

INSTALLER: Please read all instructions before servicing this equipment. Pay attention to all safety warnings and any other special notes highlighted in the manual. Safety markings are used frequently throughout this manual to designate a degree or level of seriousness and should not be ignored. **WARNING** indicates a potentially hazardous situation that if not avoided, could result in personal injury or death. **CAUTION** indicates a potentially hazardous situation that if not avoided, may result in minor or moderate injury or property damage.

REQUIREMENTS & CODES

WARNING:

This unit must be installed in accordance with instructions outlined in this manual during the installation, service, and operation of this unit. Unqualified individuals should not attempt to interpret these instructions or install this equipment. Failure to follow safety recommendations could result in possible damage to the equipment, serious personal injury or death.

- The installer must comply with all local codes and regulations which govern the installation of this type of equipment. Local codes and regulations take precedence over any recommendations contained in these instructions. Consult local building codes and the National Electrical Code (NEC) for special installation requirements.
- All electrical wiring must be completed in accordance with local, state and national codes and regulations and with the National Electric Code (ANSI/NFPA 70) or in Canada the Canadian Electric Code (CSA Z240.6.1, & Z240.9.1).
- Design and construction of the home duct system, must be in accordance with: HUD Manufactured Home Construction & Safety Standard (Title 24, Part 3280) and American National Standards (ANSI) A119.11, C1-NFPA 7
- Follow all precautions in the literature, on tags, and on labels provided with the equipment. Read and thoroughly understand the instructions provided with the equipment prior to performing the installation and operational checkout of the equipment.
- This air handler may not be used for temporary heating of buildings or structures under construction.

Minimum Installation Clearances

- Access for positioning and servicing the unit must be considered when locating unit. The need to provide clearance for access to panels or doors may require clearance distances over and above the requirements.

| ALL MODELS | CLOSET | ALCOVE |
|---------------------|--------|--------|
| FRONT ** | 6" | 18" |
| BACK | 0" | 0" |
| SIDES* | 0" | 0" |
| TOP | 0" | 0" |
| TOP & SIDES OF DUCT | 0" | 0" |
| BOTTOM OF DUCT | 0" | 0" |

*For upflow application using upflow stand, 3" minimum per side.

**Service Clearance

Table 1. Minimum Clearance Requirements

For alcove installations allow 18 (46cm) inches minimum clearance from the front of the unit for future servicing. Closet installations require 36 inches minimum.

- This appliance must be installed in accordance with clearances listed in [Table 1](#). The furnace must be installed with ample clearance for easy access to the air filter, blower assembly, burner assembly, controls, and vent connections.
- Locate and install this unit in position as specified on [page 8](#). This unit is designed only for Indoor installations and should be located with consideration of minimizing the length of the supply and return ducts. See [Table 4 \(page 15\)](#) or the rating plate for circulating airflow data.
- Sufficient clearance for unobstructed airflow through a louvered door must be maintained in order to achieve rated performance. Air return to the furnace must have the minimum required total free area:
200 in² (1290 cm²) for furnace only. May also include return air grille and frame assembly P/N 902989 or wall mount grille P/N 902999.
235 in² (1516 cm²) with 4 ton A.C. or H.P. installed.
250 in² (1613 cm²) with 4 ton A.C. or H.P. installed & 1" special clearance.
390 in² (2516 cm²) with up to 5 ton A.C. or H.P. installed.

Clearances to Combustible Materials

- This furnace is Design Certified in the U.S. and Canada by CSA International for the minimum clearances to combustible materials. **NOTE:** The furnace is listed for installation on combustible or non-combustible flooring. To obtain specific clearance information, refer to the furnace rating plate, located inside of the furnace cabinet.
- 0" from all surfaces of furnace cabinet, ducts, optional coil housing and plenum connector. No separate subbase required for installations on combustible flooring.

CIRCULATING AIR REQUIREMENTS

WARNING:

All return ducts must be secured to the furnace with sheet metal screws. All return ducts must be adequately sealed. When return air is provided through the bottom of the unit, the joint between the furnace and the return air plenum must be air tight.

Return air and circulating air ducts must not be connected to any other heat producing device such as a fireplace insert, stove, etc. This may result in fire, explosion, carbon monoxide poisoning, personal injury, or property damage.

Plenums & Air Ducts

This unit is designed only for use with a supply and return duct. Air ducts should be installed in accordance with the standards of the National Fire Protection Association Standard for Installation of Air Conditioning Systems (NFPA 90A), Standard for Installation of Residence Type Warm Air Heating and Air Conditioning Systems (NFPA 90B), and all applicable local codes. NFPA publications are available by writing to: National Fire Protection Association, Batterymarch Park, Quincy, ME 02269 or visit www.NFPA.org on the web.

- Plenums and air ducts must be installed in accordance with the Standard for the Installation of Air Conditioning and Ventilating Systems (NFPA No. 90A) or the Standard for the Installation of Warm Air Heating and Air Conditioning Systems (NFPA No. 90B).
- Design the air ducts according to methods described by the Air Conditioning Contractors of America (ACCA).
- Air ducts must be aluminum, tin plate, galvanized sheet steel, or other approved materials for outlet or return air ducts.
- Snap-Lock or Pittsburgh-Lock seams are preferred. All other types of seams must be made tight to prevent leakage.
- It is good practice to seal all connections and joints with industrial grade sealing tape or liquid sealant. Requirements for sealing ducts vary from region to region. Consult with local codes for requirements specific to your area.
- Gas piping must not run in or through any of the air duct system.
- Applicable installation codes may limit the furnace to installation in a single-story residence only. Furnace installations other than closet or alcove require ducted return air systems.

Return Air Connections

Air return to the furnace must have a minimum free area opening. See [Table 1 \(page 5\)](#). A return air grille for closet or alcove installations is available. Acceptable closet installations with return air entering through an opening in the floor or ceiling of a closet, must meet all of the following requirements:

- The return air opening, regardless of its location in the closet, must not be smaller than size specified on unit data label. If located in the floor, the opening must be provided with a means of preventing its inadvertent closure by flat object(s) placed over the opening.
- A return air grille must be used when furnace is installed in a closet or alcove:

Alcove installations: use return air grille & frame assembly P/N 902989 or equivalent. See [Figure 2 \(page 7\)](#).

Closet installations: use wall mount return air grilled P/N 902999 or equivalent. **NOTE:** For 5 ton A.C. or H.P. system, 155 in² (1,000 cm²) must be added.

Downflow alcove installations: the grille (with frame provided) may be attached to the top of the furnace and all paneling and trim flushed to it. This installation provides an access door for future installation of NORDYNE air conditioning or heat pump coils on top of the furnace.

- Materials located in return air duct system must have a flame-spread classification of 200 or less.
- Noncombustible pans having 1" upturned flanges must be located beneath openings in a floor-return duct system.
- Wiring materials located in return duct system must conform to NEC Article 300-22(c).
- If return air opening is located below top of furnace, a minimum clearance must be provided between opening and furnace. See [Table 1](#).

Supply Air Connections

- Supply duct system must be designed for proper air distribution. Static pressure measured externally to furnace shall not exceed static pressure rating listed on furnace nameplate.
- Duct system must be designed so that no supply registers are located in duct system directly below the furnace.

Acoustical Ducts

Certain installations may require the use of acoustical lining inside the supply duct work.

- Acoustical insulation must be in accordance with the current revision of the Sheet Metal and Air Conditioning Contractors National Association (SMACNA) application standard for duct liners.
- Duct lining must be UL classified batts or blankets with a fire hazard classification of FHC-25/50 or less.
- Fiber duct work may be used in place of internal duct liners if the fiber duct work is in accordance with the current revision of the SMACNA construction standard on fibrous glass ducts. Fibrous duct work and internal acoustical lining must be NFPA Class 1 air ducts when tested per UL Standard 181 for Class 1 ducts.

Unconditioned Spaces

All duct work passing through unconditioned space must be properly insulated to minimize duct losses and prevent condensation. Use insulation with an outer vapor barrier. Refer to local codes for insulation material requirements

Closed-Off Spaces

Living space not served by, and closed off from the return air ducts to the furnace (by doors, sliding partitions, and other means) must be provided with permanent, uncloseable openings in the doors or partitions to allow air to return to the furnace from all parts of the home. Return air grilles, with a minimum open area of one square inch for every five square feet of living space closed off from the furnace, must be provided in the door or room partition.

Filtering Methods - Downflow Furnaces

Non-Ducted Return Air

For unducted return air systems, either the optional grille and frame assembly or the optional wall mount grille is recommended.

Without A/C or H/P uncased coil:

- Use the filter supplied with the furnace. Make sure the filter is installed mat side down between the filter retainer and furnace top. See [Figure 2](#).

With A/C or H/P uncased coil:

- Use the optional coil filters; the filter supplied with the furnace is not used; REMOVE AND DISCARD THIS FILTER.

With optional coil housing:

- See coil cabinet instructions for specific filtering methods.

Ducted Return Air

For ducted return air systems with air conditioners or heat pumps, either providing an access panel in the duct or using the optional coil cabinet ([Figure 3](#)) is recommended. The duct system must be properly sized to account for any additional external static pressure produced from the chosen filtering method.

NOTE: Install a filter with a minimum unrestricted medium area of 324 in² in the duct above the coil that is accessible for monthly cleaning or replacement by homeowner.

Filtering Methods - Upflow Furnaces

Non-Ducted Return Air

Furnaces may be installed with unducted or ducted return air. For unducted systems with air conditioners or heat pumps, the following optional equipment is recommended: upflow stand, coil cabinet, upflow duct connector, and wall mount grille.

Without optional upflow stand:

- Install a filter with a minimum unrestricted medium area of 324 in² below the coil cabinet/furnace assembly that is accessible for monthly cleaning or replacement by the homeowner

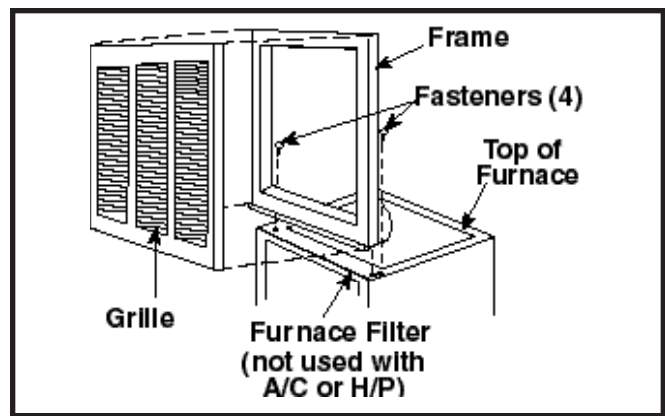

Figure 1. Grille Support Frame & Grille Assembly

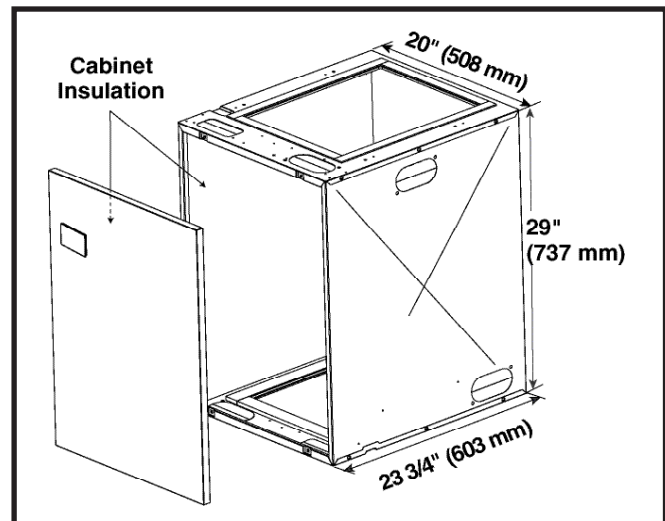

Figure 2. Upflow Coil Cabinet

With optional upflow stand:

- Stand ([Figure 4 \(page 8\)](#)) must use two filters: one is supplied with the stand and the other MUST be removed from the furnace and placed in the stand. See instructions supplied with the upflow stand for additional details.

Ducted Return Air

For ducted systems with air conditioners or heat pumps, the following optional equipment is recommended: coil cabinet and upflow duct connector.

- Install a filter with a minimum unrestricted medium area of 324 in² below the coil cabinet/furnace assembly that is accessible for monthly cleaning or replacement by the homeowner

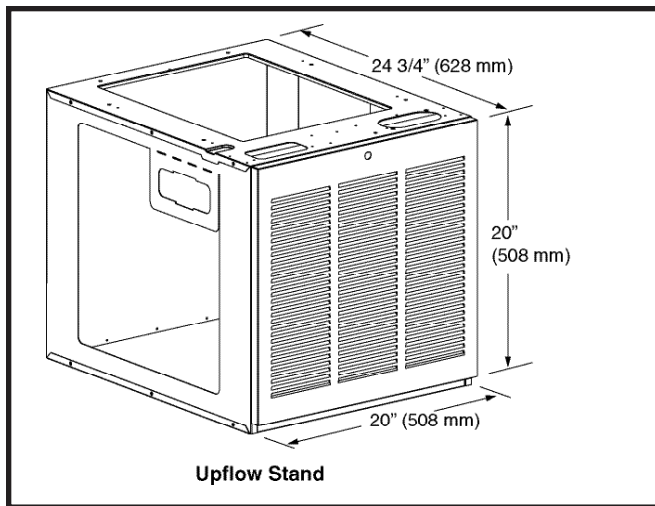

Figure 3. Optional Upflow Stand

Optional Equipment

NOTE: Refer to the instructions supplied with any additional accessories for further installation details.

Return Air Grille

A return air grille and frame assembly (Figure 2 (page 7)) is available for use in unducted return air installations. In downflow alcove installations, the grille and frame assembly may be mounted directly to the top of the furnace. In closet installations, a wall mount grille is available for attachment to a door or wall.

Optional Automatic Furnace Damper (901083)

Furnace may be equipped with the optional automatic damper when a packaged air conditioner is installed and connected to the warm air duct system. This damper (not required) prevents cooled air from discharging through the furnace cabinet, causing excessive cooling of the immediate area. Refer to the instructions supplied with the damper for details.

Duct Connectors for Downflow Systems

Duct connectors are recommended for heated air distribution in under-the-floor duct systems. With this system, furnaces may be installed on combustible flooring without a separate sub-base. The furnace rear mounting plate (Figure 8 (page 10)) supplied with the duct connectors is recommended for use with this type of installation.

FURNACE INSTALLATION

NOTE: Since all installations are different, the sequence of these steps may differ from the actual installation. These installation procedures are suggested for typical furnace installations. **Only qualified HVAC technicians should install this furnace.**

General Information

The E3 electric furnace is designed only for indoor installations and can be readily connected to the high static duct system of a home. Units are approved for single/multistory residential or mobile/modular/manufactured structures in upflow, downflow, (freestanding/closet/alcove) configurations.

This appliance will provide many years of safe and dependable comfort, providing it is properly installed and maintained. Abuse, improper use, and/or improper maintenance can shorten the life of the appliance and create unsafe hazards. Please read all instructions before installing the unit.

Approved installation, operation, and maintenance of this appliance must be in accordance with the listed specifications contained in these instructions and other documents supplied with the furnace and/or optional air conditioning equipment. Unless it is noted differently in this manual, only use factory authorized kits and accessories when modifying this appliance. Refer to local authorities having jurisdiction for further information.

Before You Install this Furnace

- ✓ This equipment is securely packaged at the time of shipment and upon arrival should be carefully inspected for damage prior to installing the equipment at the job site. Claims for damage (apparent or concealed) should be filed immediately with the carrier.
- ✓ Check the electrical supply and verify the power supply is adequate for unit operation. The system must be wired and provided with circuit protection in accordance with local building codes. If there is any question concerning the power supply, contact the local power company.
- ✓ Verify the air delivery of the furnace is adequate to handle the static pressure drop of the coil, filter, and duct work.

Locating the Unit

- Survey the job site to determine the best location for installing the unit. Consideration should be given to availability of electric power, service access, and noise.
- The dimensions of the room or alcove must be able to accommodate the overall size of the unit and the installation clearances in Table 1 (page 5). Physical dimensions for this furnace are shown in Figure 21 (page 17). If an upflow stand will be used, see Figure 22 (page 18) for component dimensions.
- The unit must be leveled at installation and attached to a properly installed duct system.
- The surface that the furnace is mounted on must provide sound physical support of the unit.

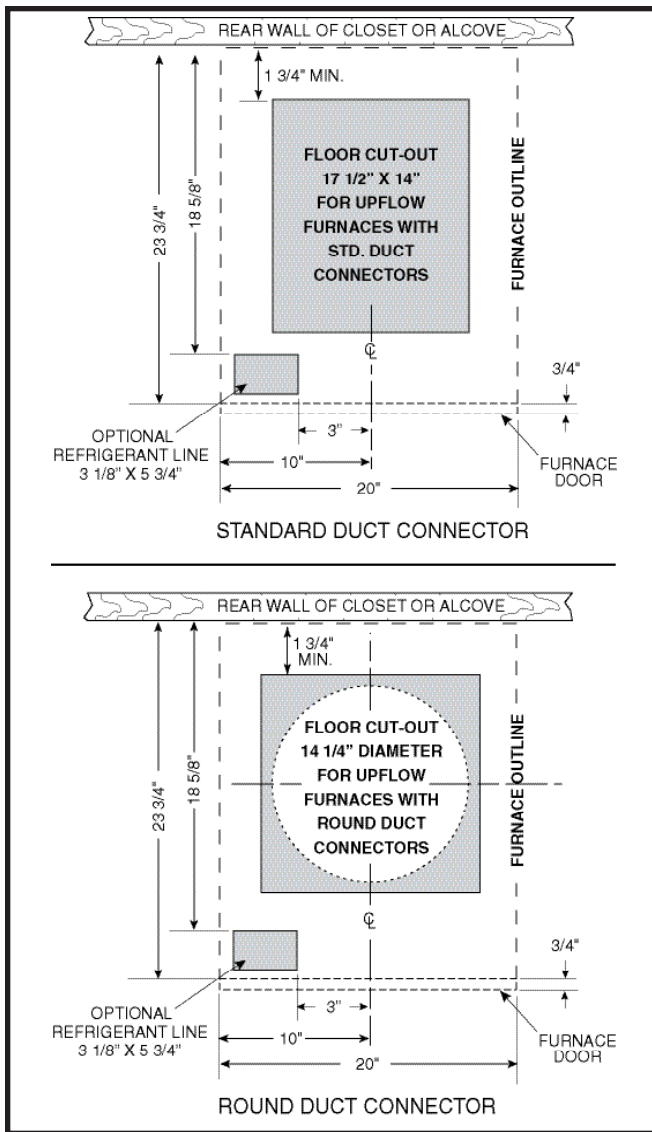

Figure 4. Cut-Out Dimensions for Upflow Furnaces

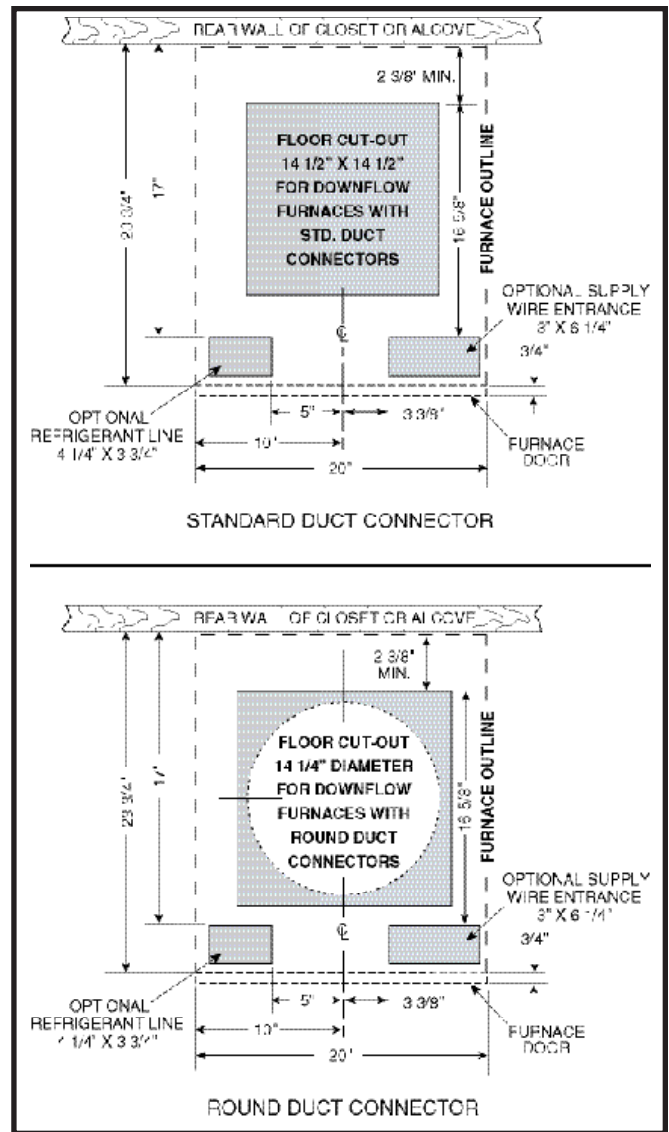

Figure 5. Cut-Out Dimensions for Downflow Furnaces

Locating & Cutting Floor Openings

Floor cut-outs must be carefully located to avoid misalignment of the furnace and air duct. Standard and round cutouts for upflow furnaces are shown in Figure 5. The cutouts for downflow furnaces are shown in Figure 6..

1. Measure and mark the centerline of the cutout. Provide minimum clearances at rear and right side walls of closet or alcove for installation of furnace and wiring.
2. Using the centerline as a starting point, draw the rest of the duct cut-out to the dimensions shown in Figure 5 or Figure 6.

NOTE: Additional provisions may be necessary for optional air conditioning or heat pump if refrigerant lines are installed elsewhere than at the front of the furnace. The refrigerant and entrance supply opening dimensions may be adjusted $\pm 1/2$ ".

3. Cut out the floor opening $1/16$ " larger than the actual cutout drawn. This will allow some clearance when installing the duct connector.

4. Measure from the top of the floor down to the top of the supply air duct to obtain the depth of the floor cavity.

NOTE: The depth of the floor cavity (shown as "X" in Figure 7) will determine the correct duct connector.

5. Determine which duct connector to use from Table 2 (page 10).

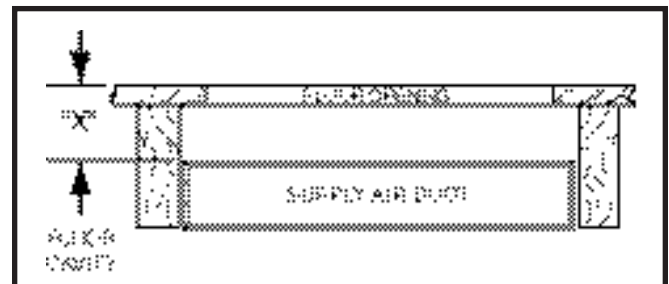

Figure 6. Floor Cavity

| IF FLOOR CAVITY "X" IS: | DUCT CONNECTOR TYPE & PART NUMBER | |
|----------------------------|--------------------------------------|------------|
| | STANDARD DUCT | SCREW DOWN |
| 7/8" / (22) | 901987A | 904008 |
| 2" / (51) | 901988A | 904009 |
| 4-1/4" / (108) | 901989A | 904010 |
| 6-1/4" / (159) | 901990A | 904011 |
| 8-1/4" / (210) | 901991A | 904012 |
| 10-1/4" / (260) | 901992A | 904013 |
| 12-1/4" / (311) | 901993A | 904014 |

NOTE: Dimensions shown as Inches / (Millimeter)

Table 2. Duct Connector Sizes

Standard Duct Connector Installation

The standard duct connector is designed for use on ducts 12" in width. **NOTE:** Ducts narrower than 12" may not allow sufficient clearances for this type of installation. See Narrow Duct Connector section.

- Center the duct connector in the floor opening with bottom tabs resting on top of the supply air duct.
- Mark the cut-out area on the supply air duct by tracing around the connector tabs of the duct connector. See [Figure 8](#).
- Remove the duct connector and cut out the marked area of the supply air duct 1/4" larger than the actual cutout drawn.
- Install the duct connector back in the floor opening with the bottom tabs extending into the supply air duct.
- Install the mounting plate ([Figure 8](#)) under the back side of the duct connector. Align the screw holes in both components.
- Secure the duct connector and the mounting plate to the wood floor with appropriate size screws.
- Bend the connector tabs on the bottom of the duct connector upwards and as tight as possible against the supply air duct. See [Figure 9](#).
- Seal all connections with industrial grade sealing tape or liquid sealant.

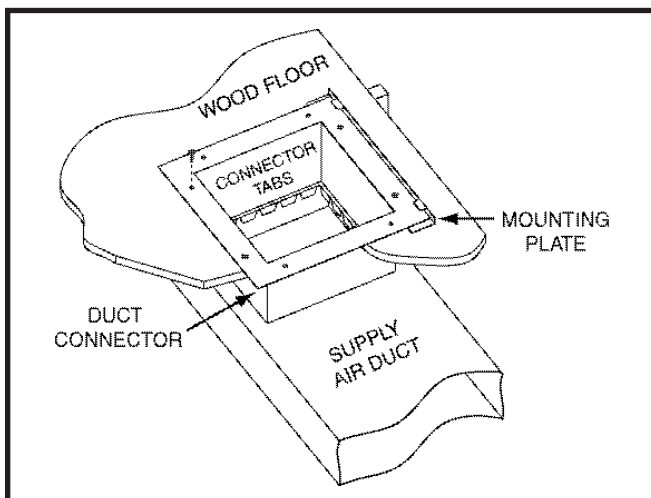

Figure 7. Standard Duct Connector Installed

NOTE: Requirements for sealing ductwork vary from region to region. Consult with local codes for requirements specific to your area.

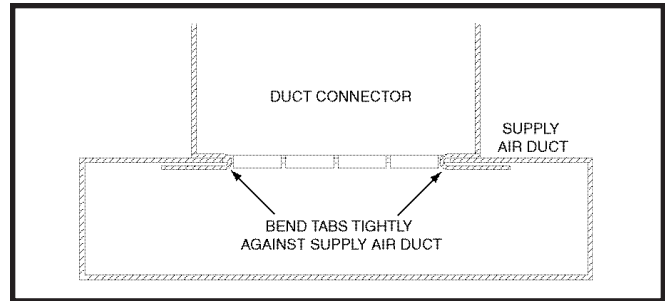

Figure 8. Duct Connector Tabs

Narrow Duct Connectors

This attachment method should be used if there is insufficient clearance to bend the tabs on a standard 12" duct connector.

- Score and cut the top of the supply air duct as indicated in Option 1 or Option 2 ([Figure 10](#)). With Option 1 choice, cut out the metal from the shaded area.
- Fold the two flaps (Options 1 or 2) up to form the opening for the duct connector.
- Install the duct connector with the bottom tabs extending into the supply air duct.
- Bend the tabs on the bottom of the duct connector upwards and as tight as possible against the supply air duct. See [Figure 11 \(page 11\)](#).
- Form the flaps (Options 1 or 2) up against the duct connector as tight as possible.
- Secure the duct connector flaps to the supply air duct with staples (3 minimum) or if a 2x block/joist is not provided, use sheet metal screws (2 minimum). **NOTE:** The duct connector tabs may be attached to the air duct with sheet metal screws or other suitable fasteners as long as the duct connector and the air duct are securely attached.
- Seal all connections with industrial grade sealing tape or liquid sealant.

NOTE: Requirements for sealing ductwork vary from region to region. Consult with local codes for requirements specific to your area.

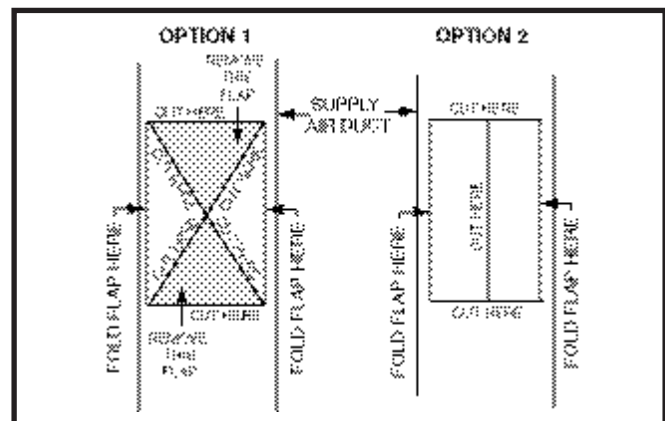

Figure 9. Narrow Air Duct Openings

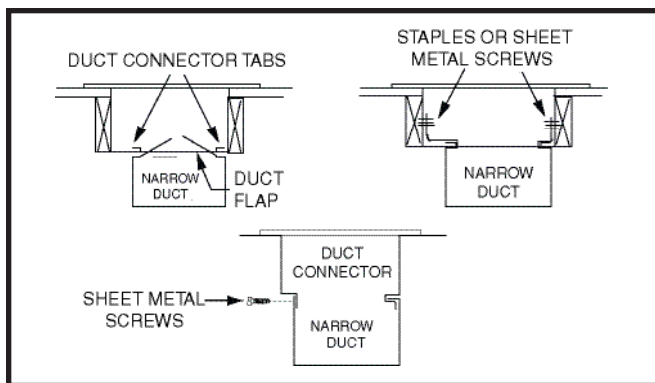

Figure 10. Narrow Ducts

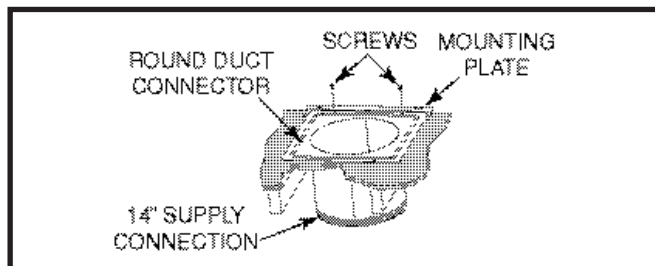

Figure 11. Round Duct Connector Installed

Round Duct Connector Installation

The 14" round duct connector is designed to connect directly to a 14" flexible duct. **NOTE:** Flexible ducts must have a minimum temperature rating of 200° F and meet all applicable codes and standards.

1. Apply a bead of caulking, mastic, or other approved sealant around bottom side of connector.
2. Install and center the duct connector in the floor opening.
3. Install the mounting plate under the back side of the duct connector. See [Figure 12](#). **NOTE:** Align the screw holes in both components.
4. Secure the duct connector and the mounting plate to the wood floor with appropriate size screws.
5. Connect the round supply duct to the underside of the duct connector and secure them with field supplied sheet metal screws.
6. Seal all connections with industrial grade sealing tape or liquid sealant.

NOTE: Requirements for sealing ductwork vary from region to region. Consult with local codes for requirements specific to your area.

Alcove Installation

1. Cut alcove rough openings to minimum dimensions shown in [Figure 13](#).
2. Attach frame assembly with four fasteners (provided or equivalent) into pre-punched holes on top of furnace. See [Figure 2](#) (page 7). **NOTE:** If additional securing is required, attach each side of frame assembly to alcove opening using holes provided.
3. Attach return air grille to frame assembly by hooking grille over flange on top of frame and into channel on bottom.

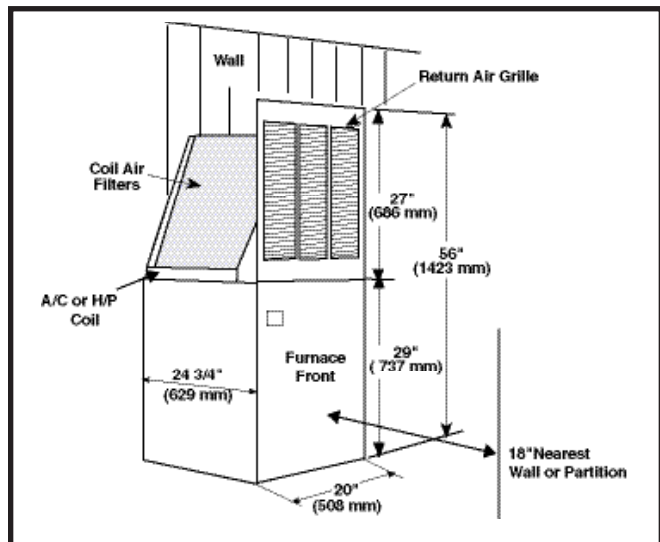

Figure 12. Alcove Installation

Closet Installation

For proper air circulation, closet installations require a return air grille installed in the door or a partially louvered door across the opening. For clearances 6" or greater, the closet must have an open free area of 235 in² minimum. For special clearances between 1" - 5", requirements are a louvered door with a minimum of 250 in² (1613 cm²) free area. A fully louvered closet door is strongly recommended for both installation types. For closet installations, the return air grille mounting frame is not used since the furnace is located inside the closet. For examples of both types of installations, see [Figure 14](#) (page 12).

1. Cut return air opening in desired position in door or wall, preferably above top of furnace. Refer to [Table 1](#) (page 5) for return air opening requirements.
2. Insert four fasteners, securing grille to door or wall.

Downflow Furnaces

For typical unducted return air downflow applications, an air-conditioner or heat-pump coil can be installed by mounting the coil directly on top of the furnace without adding sheet metal cavities or cutting and trimming wood panels. Unducted return air systems may be used for closet or alcove installations.

The steps below describe installation procedures for an under-the-floor supply duct system with a ducted or unducted return air system. Duct connectors are recommended for this application. See [Table 2](#) (page 10).

1. Route 240V supply circuit(s) and 24V wiring to closet or alcove. See [Figure 21](#) (page 17) for locations.
2. Remove refrigerant line knockouts in furnace only when installing indoor coil of an air conditioner or heat pump system, or for hook-up of a VentilAire accessory when the furnace is used in the upflow position. Refer to instructions supplied with accessory equipment.
3. Remove unit front door and slide back until bottom slots in rear of unit engage with both tabs of optional rear mounting plate. If mounting plate is not used, an

equivalent method of securing the rear of the unit may be used as long as it prevents displacement during transport if used in a manufactured home.

NOTE: The furnace does not need to be positioned against the rear mounting plate. The tabs will engage into the slots and allow approximately 1/2" of furnace adjustment front to back and side to side.

4. Secure front of unit with one or more fasteners at mounting hole(s) provided or at tie-down tab. See [Figure 20 \(page 17\)](#).
5. See Electrical Wiring section ([page 13](#)) to complete furnace installation.

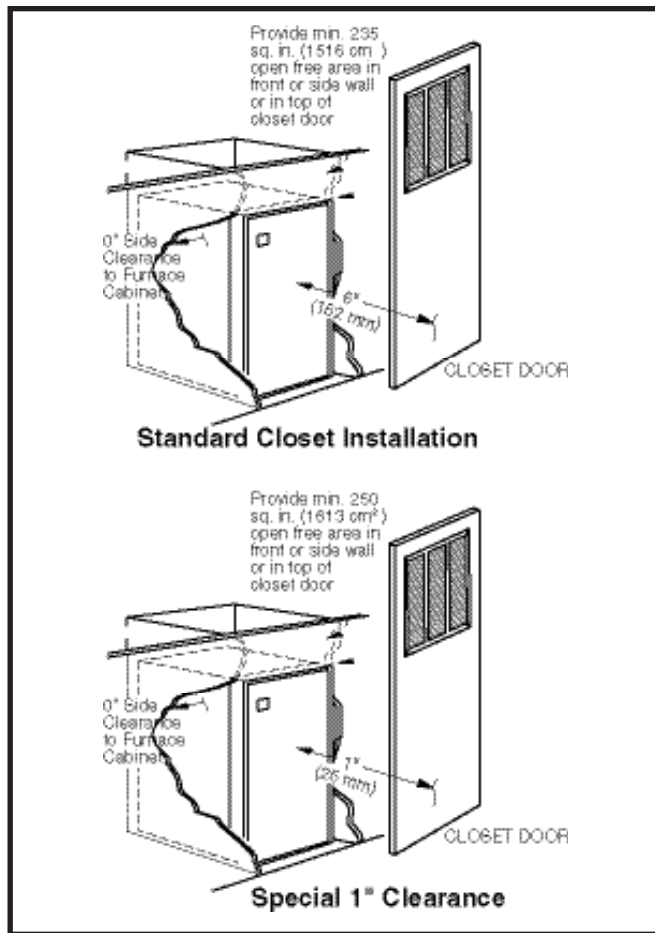

Figure 13. Closet Installation

Upflow Furnaces

The following steps describe installation instructions for an overhead supply duct system with a return air system that can be either over the floor (unducted) or through the floor (ducted).

NOTE: Remove refrigerant line knockouts in furnace only when installing indoor coil from an air conditioner or heat pump system.

Refer to instructions supplied with accessory equipment.

Over-the-Floor Return Air System (Non-Ducted)

1. If floor underneath furnace is made of combustible material, locate a pan fabricated of non-combustible material with 1" upturned flanges under furnace return air opening. See [Figure 15](#).
2. Use optional upflow stand with filters or construct a suitably braced mounting platform in closet. See [Figure 16 \(page 13\)](#).
3. Route 240V supply circuit(s) and 24V wiring to closet. See [Figure 21 \(page 17\)](#) for appropriate locations.
4. Position optional coil cabinet onto upflow stand or mounting platform and secure with three or more fasteners.
5. Position furnace in upflow mode onto coil cabinet and secure with two or more fasteners.
6. Use optional upflow duct connector or field supplied connector to attach furnace to overhead supply duct. See [Figure 16](#).
7. Install return air grille in closet preferably at same level as upflow stand or below mounting platform. See [Figure 15](#).

NOTE: Be sure to provide an adequate free return air area as described in the Closed-Off Spaces section ([page 7](#)).

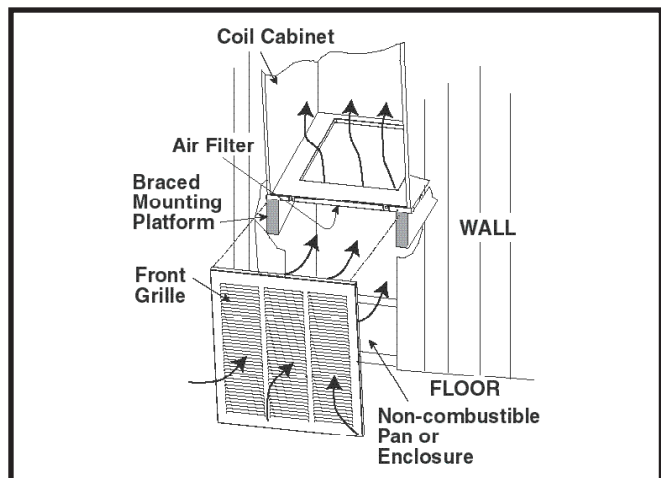

Figure 14. Over-the-Floor Return Air System

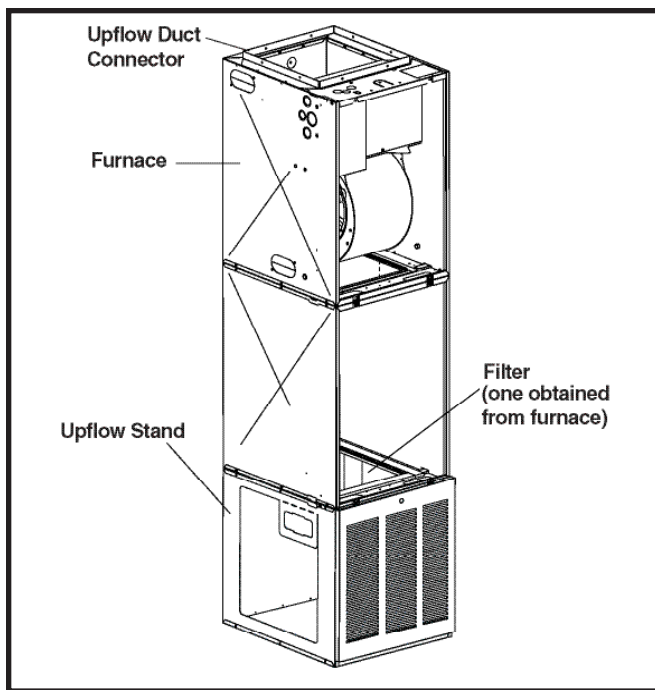

Figure 15. Over-the-Floor Return Air System with Upflow Stand

Through-the-Floor Return Air System (Ducted)

1. Prepare Floor Opening(s):
 - a. Mark floor openings as shown in [Figure 5 \(page 9\)](#). Provide minimum clearances at rear and left side walls of closet for installation of furnace and wiring.
 - b. Cut floor opening on outside edge of marked line so that opening is slightly larger than area marked.
 - c. Additional provisions may be necessary for optional air conditioning if refrigerant lines are installed other than at the front of the furnace.
2. If return air duct is made of combustible material, locate a pan fabricated of non-combustible material with 1" upturned flanges under furnace return air opening.
3. Route 240V supply circuit(s) and 24V wiring to closet. See [Figure 21 \(page 17\)](#) for appropriate locations.
4. Position optional coil cabinet over floor cutout and secure with three or more fasteners.
5. Position furnace onto coil cabinet and secure with two or more fasteners.
6. Use optional upflow duct connector or field supplied connector to attach furnace to overhead supply duct. See [Figure 16](#).

ELECTRICAL WIRING

⚠ WARNING:

ELECTRICAL SHOCK, FIRE OR EXPLOSION HAZARD

Failure to follow safety warnings exactly could result in serious injury or property damage.

Improper servicing could result in dangerous operation, serious injury, death or property damage.

- Before servicing, disconnect all electrical power to furnace.
- When servicing controls, label all wires prior to disconnecting. Reconnect wires correctly.
- Verify proper operation after servicing."

⚠ AVERTISSEMENT:

RISQUE DE CHOC ÉLECTRIQUE, D'INCENDIE OU D'EXPLOSION

Le non-respect des avertissements de sécurité pourrait entraîner un fonctionnement dangereux de l'appareil, des blessures graves, la mort ou des dommages matériels.

Un entreteïn incorrect pourrait entraîner un fonctionnement dangereux de l'appareil, des blessures graves, la mort ou des dommages matériels

- Couper toute alimentation électrique au générateur d'air chaud avant de prodéder aux travaux d'entreteïn.
- Au moment de l'entreteïn des commandes, étiquetez tous les fils avant de les débrancher. S'assurer de les raccorder correctement.
- S'assurer que l'appareil fonctionne adéquatement après l'entreteïn.

- Electrical connections must be in compliance with all applicable local codes and the current revision of the National Electric Code (ANSI/NFPA 70).
- For Canadian installations the electrical connections and grounding shall comply with the current Canadian Electrical Code (CSA C22.1 and/or local codes).

Line Voltage Wiring

IMPORTANT NOTES

- Proper line voltage polarity must be maintained for the control system to operate correctly. Verify the incoming neutral line is connected to the white wire and the incoming hot line is connected to the black wire. The furnace will not operate unless the polarity and ground are properly connected.

- **Circuit breakers installed in this unit provide short-circuit protection of the internal wiring and serve as a disconnect. The circuit breakers DO NOT provide over-current protection of the supply wiring and may be sized larger than the branch circuit protection. Overcurrent protection of the supply wiring is provided by the breaker in the distribution panel and must be sized as shown in Table 7 (page 19).**

It is recommended that the line voltage (240 VAC) to the furnace be supplied from a dedicated branch circuit containing the correct fuse or circuit breaker for the furnace. For minimum circuit ampacity and maximum over-current protection, see Table 7 (page 19). See unit wiring diagrams (Figure 23, Figure 24, Figure 25, & Figure 26) for wiring details. Electrical components are shown in Figure 20 (page 17). Supply circuit requirements are listed below:

- -010 model is factory-wired for single-branch supply circuit only.
- -012 models are factory-wired for single-branch supply circuit (single-circuit kit factory installed). Dual-branch circuit can be used by removing factory-installed single-circuit kit. See Figure 17.
- -015, -017, -020 and -023 models are factory-wired for dual-branch supply circuit. Single-branch circuit can be used by installing optional single-circuit kit.

Connecting Supply Service Wires

Power entrance for all models may be through the right side or through the bottom of the unit.

1. Remove right-hand control panel (when viewing in downflow position).
2. Locate power supply knockouts in side of unit and in bottom of unit. Remove appropriate plug(s) or knockout opening applicable to selected wire size(s).

⚠ WARNING:

To avoid personal injury or property damage, make certain that the motor leads cannot come into contact with non-insulated metal components of the unit.

3. Install listed cable connector(s) in opening(s). If metal-sheathed conduit is used for incoming power line(s), provide an approved metal clamp on conduit and secure it in entrance knockout.
4. Insert supply service wire(s) through cable connector(s) and connect wires to circuit breakers (Figure 17 & Figure 18). **NOTE:** To install single-circuit kit, perform step 5. If single-circuit kit installation is not needed, go to step 6.
5. To install optional single-circuit kit:
 - a. Loosen lugs at supply side of circuit breakers.
 - b. Remove cover from single-circuit kit (if supplied).
 - c. Insert metal buss bars of kit into lugs of circuit breaker.
 - d. Tighten lugs securely (45 in.-lbs. recommended).
6. Connect service ground wire(s) to grounding lug(s) provided. One ground is required for each supply circuit used. See Figure 20 (page 17).

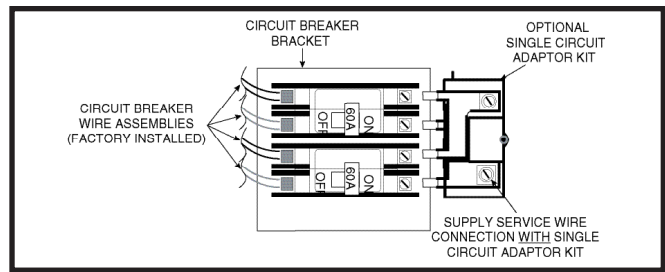

Figure 16. Optional Single Circuit Adaptor Kit

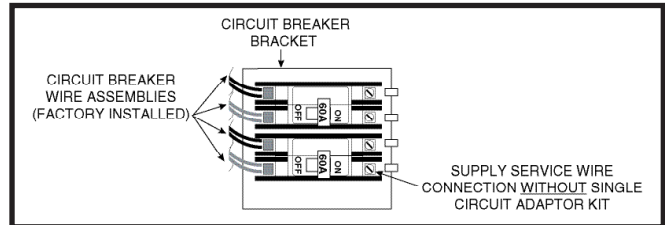

Figure 17. Installation of Supply Service Wires

Grounding

⚠ WARNING:

To minimize personal injury, the furnace cabinet must have an uninterrupted or unbroken electrical ground. The controls used in this furnace require an earth ground to operate properly. Acceptable methods include electrical wire or conduit approved for ground service. Do not use gas piping as an electrical ground!

Thermostat / Low Voltage Connections

- The furnace is designed to be controlled by a 24 VAC thermostat. The thermostat's wiring must comply with the current provisions of the NEC (ANSI/NFPA 70) and with applicable local codes having jurisdiction.
- The thermostat should be mounted about 5 feet above the floor on an inside wall. DO NOT install the thermostat on an outside wall or any other location where its operation may be adversely affected by radiant heat from fireplaces, sunlight, or lighting fixtures, and convective heat from warm air registers or electrical appliances. Refer to the thermostat manufacturer's instruction sheet for detailed mounting information.

Selecting Blower Speed

The E3EB model is equipped with a 4-speed PSC motor which can be upgraded to a multi-speed high efficiency X-13 motor using kit 904619. It is equipped with a multi-speed blower, blower relay, and cabinet insulation kit for air conditioner hookup. See Table 5 (page 15) for cooling and heat pump availability with factory installed blower.

See Table 3 (page 15) for the lowest speed approved for the heating output of the unit. Since the blower leads connect to the control box, blower speed selection is through use of the proper color-coded blower lead located

| PLUG / RECEPTACLE POSITION | PIN 1 | PIN 2 | PIN 3 | PIN 4 | PIN 5 |
|----------------------------|-------|--------|--------|-------|-------|
| 4 SPEED BLOWER | Low | Med-LO | Med-Hi | High | - |
| CONTROL BOX BLOWER LEAD | Red | Yellow | Blue | Black | - |

Table 3. Furnace Blower Speed Data

| 4-TON BLOWER WITH COIL AND COIL AND FILTERS, @ 0.3" ESP | | |
|---|-----------|-------|
| PIN NO. | SPEED | CFM |
| #1 | Low | 880 |
| #2 | Med.-Low | 1,170 |
| #3 | Med.-High | 1,310 |
| #4 | High | 1,460 |
| 5-TON BLOWER, WITH COIL AND COIL FILTERS, @ 0.3" ESP | | |
| PIN NO. | SPEED | CFM |
| #1 | Low | 990 |
| #2 | Med.-Low | 1,320 |
| #3 | Med.-High | 1,620 |
| #4 | High | 1,790 |
| MULTI-SPEED, X13, BLOWER, WITH COIL AND FILTERS, @ 0.3" ESP | | |
| PIN NO. | SPEED | CFM |
| #1 | Low | 880 |
| #2 | Med.-Low | 1,000 |
| #3 | Med | 1,170 |
| #4 | Med.-High | 1,260 |
| #5 | High | 1,460 |

Table 4. Blower Performance

| FURNACE MODEL | T-STAT ANTICIPATOR SETTING |
|--------------------|----------------------------|
| 010, 012 | 0.2 |
| 015, 017, 020, 023 | 0.4 |

Table 5. Anticipator Settings

inside the control box. The speed(s) set by the factory may be different from that shown on the wiring diagrams. See the unit control box for factory set blower speed(s).

Changing Blower Speed

The selected heating blower lead is attached to terminal 6 of the blower relay. The selected cooling blower lead is attached to terminal 4 of the blower relay.

- **For New Heating Speed:** Remove heating blower lead from terminal 6 of the blower relay. Choose desired speed and install new blower lead on terminal 6 of the blower relay.
- **For New Cooling Speed:** Remove cooling blower lead from terminal 4 of the blower relay. Install new blower lead on terminal 4 of the blower relay.
- **Same Speed, Heating & A/C:** Use white jumper wire supplied with unit and jumper between terminals 5 & 2 on blower relay. See [Table 4](#) for blower performance data.

Blower Installation

1. Turn off all electrical supply circuits to the furnace at the main service panel.
2. Remove furnace front door and switch furnace circuit breaker(s) to OFF.
3. Disconnect the motor plug from the control panel receptacle.
4. Remove one screw from left side of blower and three screws from right side of blower. Slide blower forward to remove.
5. Install new blower. **NOTE:** Make sure the side flanges engage under side mounting tabs. Three tabs on one side and one on the other. The long tab is in the rear.
6. Replace screws removed from blower in step 4.
7. Connect the motor plug to the control panel receptacle.
8. Switch circuit breaker(s) to ON.
9. Reinstall furnace front door and turn on electrical supply circuits to the furnace.

Installing Control Circuit Wiring

NOTE: Installation of a five-wire thermostat circuit is recommended for future addition of a heat/cool thermostat. See [Figure 19 \(page 16\)](#) for various E3EB thermostat connections.

1. Install the 24V control-circuit cable through plastic bushing at either side of furnace.
2. Route control circuit wiring to wall thermostat and outdoor section, if installed.
3. Set anticipator to the setting listed on the units rating label or in [Table 5](#).

START-UP & ADJUSTMENTS

Pre-Start Check List

- ✓ Verify the polarity of the connections are correct, the line voltage power leads are securely connected and the furnace is properly grounded. Refer to the appropriate wiring diagram.
- ✓ Verify the thermostat wires are securely connected to the correct leads on the terminal strip of the circuit board.
- ✓ Check blower motor and relay box connectors for proper connection.

Start-up Procedures

1. Reinstall control box cover(s).
2. Switch circuit breaker(s) to the ON position.
3. Replace outer furnace door.
4. Check all duct connections and tape for air leakage.

FIGURES & TABLES

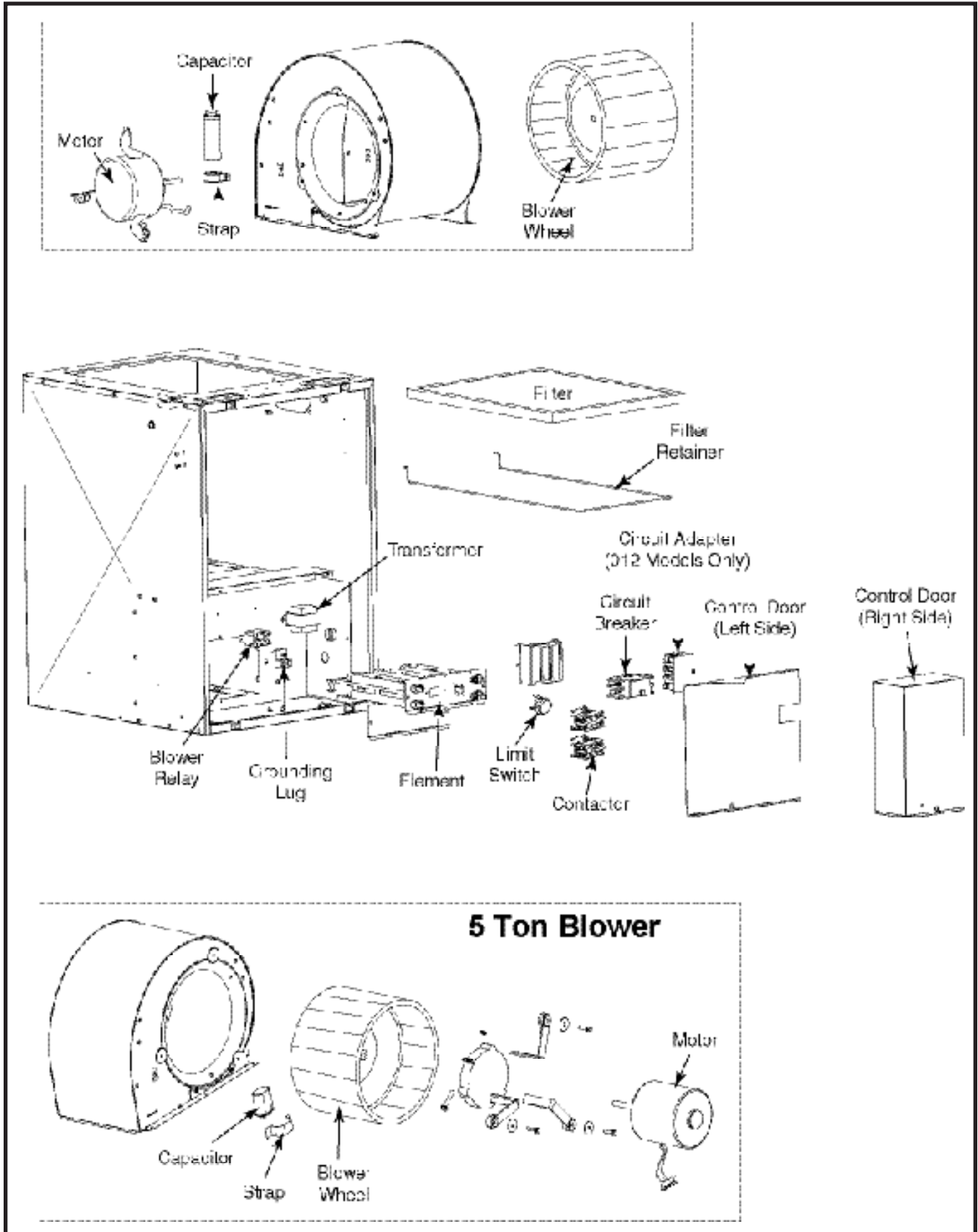

Figure 18. E3 Furnace Components

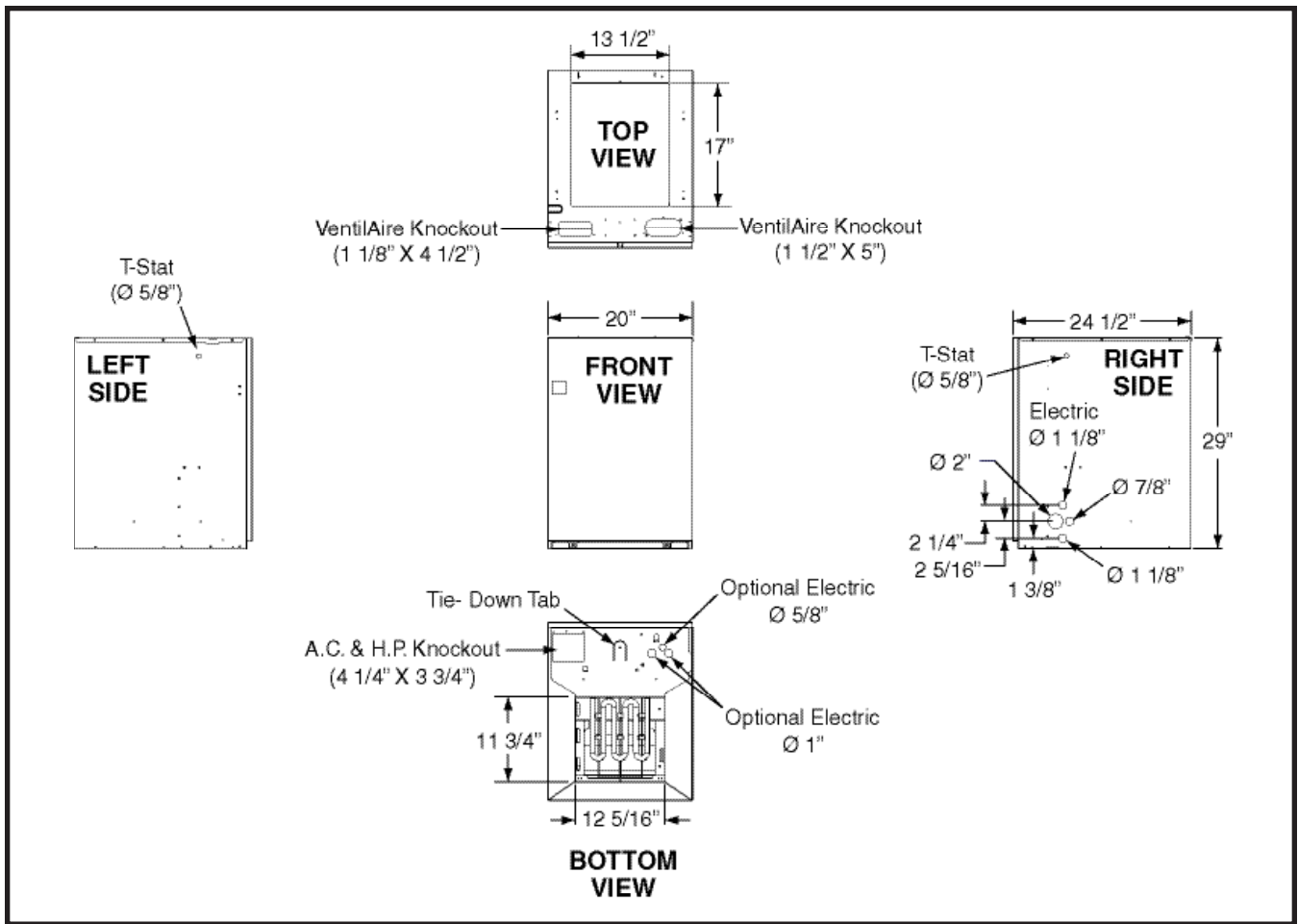

Figure 19. E3 Furnace Physical Dimensions

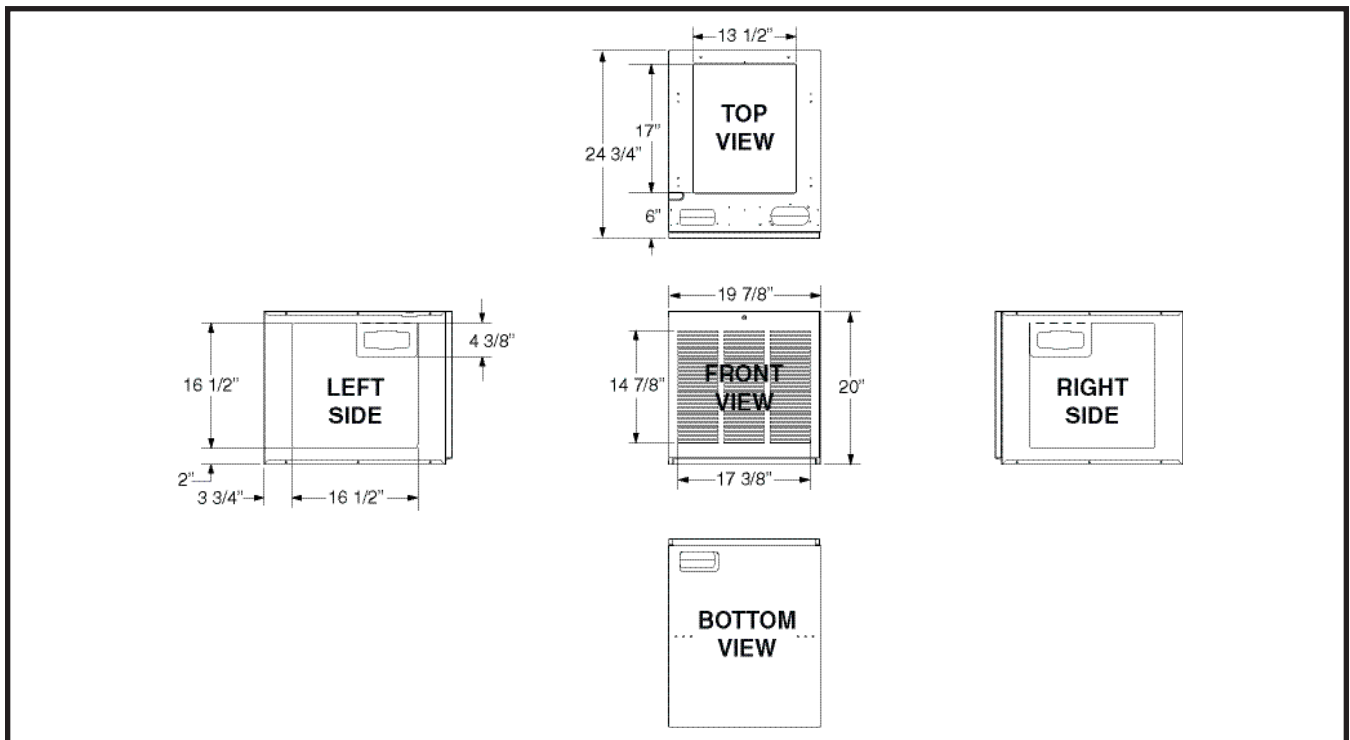

Figure 20. E3 Furnace Upflow Stand Dimensions

Electrical Data

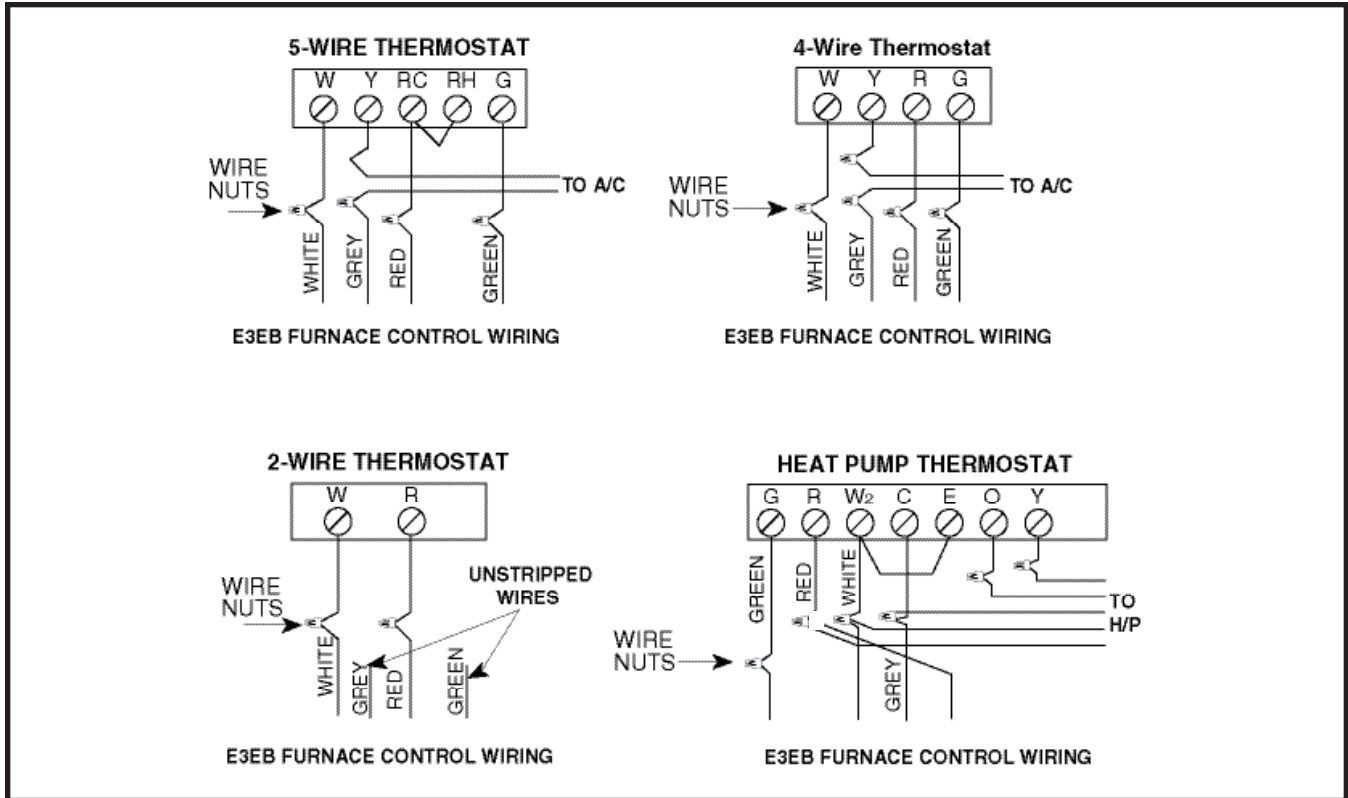

Figure 21. E3EB Thermostat Connection

| FURNACE MODELS E3EB- | 010H | 012H | 015H | 017H | 020H | 023H | 023H 5-TON |
|--|---|--------------------|--------------------|--------------------|--------------------|--------------------|---------------------------|
| RATED HEATING OUTPUT, BTUH (SEE NOTE 1) | 35,000 | 41,000 | 53,000 | 57,000 | 70,000 | 75,000 | 75,000 |
| WATTS (TOTAL KW, HEATING ELEMENTS & BLOWER) | 10.4 | 12.0 | 15.4 | 16.6 | 20.4 | 22.0 | 22.0 |
| SUPPLY VOLTAGE | 240 Volts/60Hz/1-Phase | | | | | | |
| HEATING ELEMENTS, No. (TOTAL KW) | 2 (10.0) | 2 (11.6) | 3 (15.0) | 3 (16.2) | 4 (20.0) | 4 (21.6) | 4 (21.6) |
| BLOWER WHEEL SIZE | 10.5" Dia, 8" W | 10.5" Dia, 8" W | 10.5" Dia, 8" W | 10.5" Dia, 8" W | 10.5" Dia, 8" W | 10.5" Dia, 8" W | 11" Dia., 8" W |
| MOTOR SPEED, H.P. RATING, AMPS | 4 Speed, 1/3 HP, 2.9 | | | | | | 4 Spd, 3/4HP, 3.8 Amps |
| TEST ESP, IN. W.C. MAX | 0.3 | | | | | | |
| OPTIONAL COOLING AVAILABLE WITH FACTORY INSTALLED BLOWER | 2.0 - 4.0 Ton (See Note 3) | | | | | | 2.0 - 5.0 Ton |
| OPTIONAL HEAT PUMP AVAILABLE WITH FACTORY INSTALLED BLOWER | 2.0 - 4.0 Ton | | | | | | |
| AIR FILTER (STANDARD) | 16" x 20" x 1" (nominal) | | | | | | |
| FURNACE DIMENSIONS | Width-20" (508mm), Height-29" (737mm) (see note 2), Depth-24 1/2" (623mm) | | | | | | |

NOTES:

1. Heating output rated at listed voltage. For outputs at voltages other than 240V, multiply Btuh rating by the following factors: x 0.92 (230V), x 0.84 (220V), x 0.75 (208V).
2. Height is 56" with return air grille installed, 58" with coil cabinet and 72" with coil cabinet and upflow stand.
3. The factory installed blower for the EB models can be replaced with a multi-speed blower allowing the units to accept up to 5 tons of air conditioning.

Table 6. Unit Specifications

| MODEL NUMBER E3EB- | SUPPLY CIRCUIT | TOTAL AMPERES | MAXIMUM OVER-CURRENT RATING | MINIMUM CIRCUIT AMPACITY | LOW VOLTAGE THERMOSTAT WIRE SIZE |
|-----------------------|----------------|---------------|-----------------------------|--------------------------|--|
| 010H | Single | 44.6 | 60 | 56 | 2-Wire system maximum wire lengths: 24 Ga. = 55' 22 Ga. = 90' 20 Ga. = 140' 18 Ga. = 225' |
| 012H | Single | 51.2 | 70 | 64 | |
| | Dual "A" | 27.1 | 40 | 34 | |
| 015H | Dual "B" | 24.2 | 30 | 30 | |
| | Single | 65.4 | 90 | 82 | |
| | Dual "A" | 44.6 | 60 | 56 | |
| 017H | Dual "B" | 20.8 | 30 | 26 | |
| | Single | 70.4 | 90 | 88 | |
| | Dual "A" | 47.9 | 60 | 60 | |
| 020H | Dual "B" | 22.5 | 30 | 28 | 4 or more wire systems maximum wire lengths: 24 Ga. = 25' 22 Ga. = 45' 20 Ga. = 70' 18 Ga. = 110' |
| | Single | 86.2 | 125 | 108 | |
| | Dual "A" | 44.6 | 60 | 56 | |
| 023H | Dual "B" | 41.7 | 60 | 52 | |
| | Single | 93.8 | 125 | 117 | |
| | Dual "A" | 45.5 | 60 | 57 | |
| 023H | Dual "B" | 48.0 | 60 | 60 | |

| MODEL NUMBER E3EX- | SUPPLY CIRCUIT | TOTAL AMPERES | MAXIMUM OVER-CURRENT RATING | MINIMUM CIRCUIT AMPACITY | LOW VOLTAGE THERMOSTAT WIRE SIZE | |
|-----------------------|----------------|---------------|-----------------------------|--------------------------|--|---|
| 010 | Single | 47.7 | 60 | 57 | 2-Wire system maximum wire lengths: 24 Ga. = 55' 22 Ga. = 90' 20 Ga. = 140' 18 Ga. = 225' | |
| 012 | Single | 54.3 | 70 | 67 | | |
| | Dual "A" | 30.2 | 40 | 35 | | |
| 015 | Dual "B" | 24.2 | 30 | 30 | | |
| | Single | 66.0 | 90 | 83 | | |
| | Dual "A" | 46.0 | 60 | 57 | | |
| 017 | Dual "B" | 20.0 | 30 | 25 | | 4 or more wire systems maximum wire lengths: 24 Ga. = 25' 22 Ga. = 45' 20 Ga. = 70' 18 Ga. = 110' |
| | Single | 71.5 | 90 | 89 | | |
| | Dual "A" | 51.0 | 60 | 60 | | |
| 020 | Dual "B" | 22.5 | 30 | 28 | | |
| | Single | 86.0 | 125 | 109 | | |
| | Dual "A" | 46.0 | 60 | 57 | | |
| 020 | Dual "B" | 40.0 | 60 | 50 | | |

NOTE: Wire size must be in accordance to the applicable revision of the NEC and all other applicable codes.

Table 7. E3 Electrical Specifications

Wiring Diagrams

WIRING DIAGRAM

Model: E3EB-010H

WARNING

Substitute breakers to the "off" position before servicing the furnace.

NOTES:

1. Supply wire size must be in accordance to the applicable revision of the NEC and all other applicable codes.
2. Thermostat anticipator setting: 0.20 Amps
3. To change blower speed on units without a relay box installed refer to installation instructions
4. Refer to furnace and/or relay box installation instructions for thermostat connections.
5. If any wire in this Unit is to be replaced it must be replaced with 105° C thermoplastic copper wire of the same gauge.
6. Not suitable for use on systems exceeding 120V to ground.
7. Refer to installation instructions for complete wiring diagram.
8. Heating and cooling may be wired on the same speed using either a relay box or the provided jumper wire.

AVERTISSEMENT

Remplacez les disjoncteurs en position « off » avant d'intervenir à l'installation.

1. La taille du câblage d'alimentation doit être conforme à la révision applicable des codés NEC et des autres codés applicables.
2. Réglage d'anticipation du thermostat : 0,20 A
3. Pour changer la vitesse du ventilateur sur les unités sans boîte de relais, consultez les instructions d'installation.
4. Consultez les instructions d'installation de la fournaise ou de la boîte de relais pour les branchements du thermostat.
5. Si l'un ou l'autre des fils de cette unité requiert un remplacement, il doit être remplacé par un fil en cuivre thermoplastique 105 °C du même gabarit.
6. Ne convient pas à l'utilisation sur les systèmes qui excèdent 120 V à la terre.
7. Consultez les instructions d'installation pour un schéma de câblage complet.
8. Le chauffage et la climatisation peuvent être câblés sur la même vitesse à l'aide d'une boîte de relais ou du cavalier fourni.

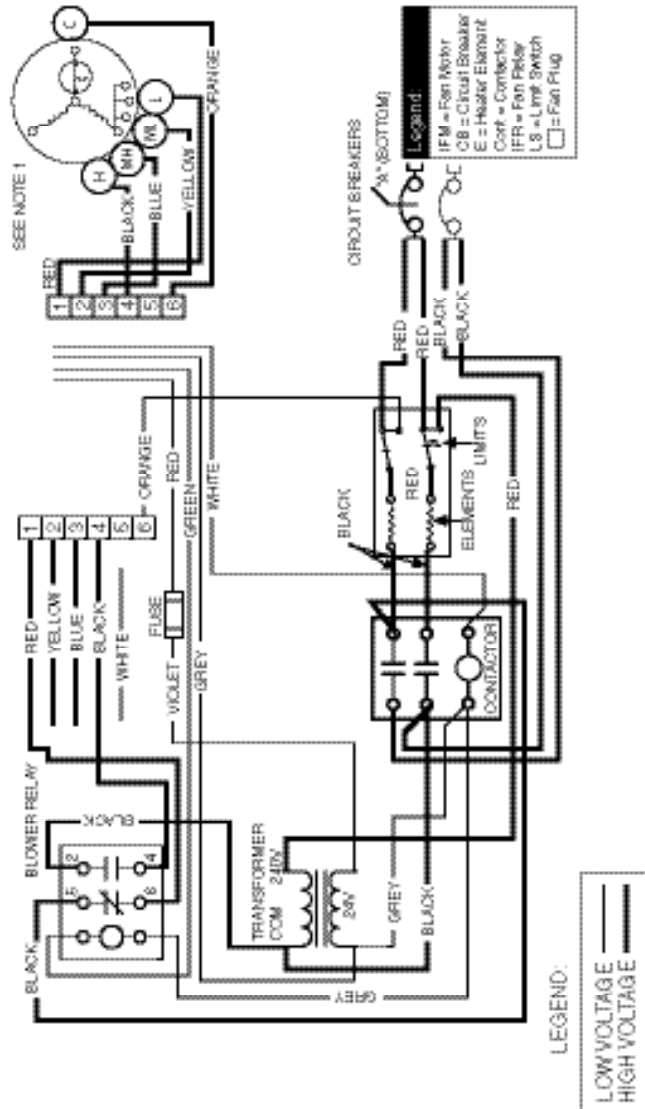

7112680
01 13

Figure 22. E3EB-010H Models

WIRING DIAGRAM

Model: E3EB-012H

WARNING
Switch circuit breakers to the "off" position before servicing the furnace.

NOTES:

1. Supply wire size must be in accordance to the applicable revision of the NEC and all other applicable codes.
2. Thermostat anticipator setting: 0.40 Amps
3. To change blower speed on units without a relay box installed refer to installation instructions
4. Refer to furnace and/or relay box installation instructions for thermostat connections.
5. If any wire in this unit is to be replaced it must be replaced with 105° C thermoplastic copper wire of the same gauge.
6. Not suitable for use on systems exceeding 120V to ground.
7. Refer to installation instructions for complete wiring diagram.
8. Heating and cooling may be wired on the same speed using either a relay box or the provided jumper wire.

AVERTISSEMENT
Placez les dipositifs en position «off» avant d'effectuer la maintenance.

1. La taille du câblage d'alimentation doit être conforme à la révision applicable des codes NEC et des autres codes applicables.
2. Réglage d'anticipation du thermostat : 0.40A
3. Pour changer la vitesse du ventilateur sur les unités sans boîte de relais, consultez les instructions d'installation.
4. Consultez les instructions d'installation de la fournaise ou de la boîte de relais pour les branchements du thermostat.
5. Si l'un ou l'autre des fils de cette unité requiert un remplacement, il doit être remplacé par un fil en cuivre thermoplastique 105 °C du même gabarit.
6. Ne convient pas à l'utilisation sur les systèmes qui excèdent 120 V à la terre.
7. Consultez les instructions d'installation pour un schéma de câblage complet.
8. Le chauffage et la climatisation peuvent être câblés sur la même vitesse à l'aide d'une boîte de relais ou du cavalier fourni.

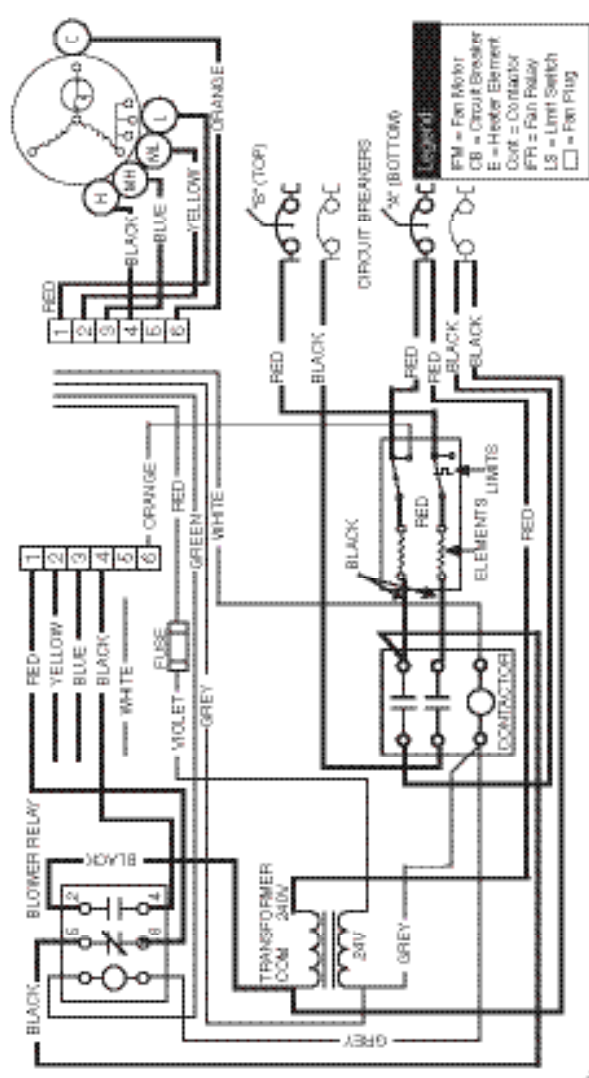

LEGEND:
LOW VOLTAGE
HIGH VOLTAGE

711269A
0414

Figure 23. E3EB-012H Models

WIRING DIAGRAM

Model: E3EB-015H-017H



NOTES:

1. Supply wire size must be in accordance to the applicable revision of the NEC and all other applicable codes.
 2. Thermostat anticipator setting: 0.40 Amps
 3. To change blower speed on units without a relay box installed refer to installation instructions
 4. Refer to furnace and/or relay box installation instructions for thermostat connections.
 5. If any wire in this unit is to be replaced it must be replaced with 105° C thermoplastic copper wire of the same gauge.
 6. Not suitable for use on systems exceeding 120V to ground.
 7. Refer to installation instructions for complete wiring diagram.
 8. Heating and cooling may be wired on the same speed using either a relay box or the provided jumper wire.
1. La taille du câblage d'alimentation doit être conforme à la révision applicable des codes NEC et des autres codes applicables.
 2. Réglage d'anticipation du thermostat : 0,40 A
 3. Pour changer la vitesse du ventilateur sur les unités sans boîte de relais, consultez les instructions d'installation.
 4. Consultez les instructions d'installation de la fournaise ou de la boîte de relais pour les branchements du thermostat.
 5. Si l'un ou l'autre des fils de cette unité requiert un remplacement, il doit être remplacé par un fil en cuivre thermoplastique 105 °C du même gabarit.
 6. Ne convient pas à l'utilisation sur les systèmes qui excèdent 120 V à la terre.
 7. Consultez les instructions d'installation pour un schéma de câblage complet.
 8. Le chauffage et la climatisation peuvent être câblés sur la même vitesse à l'aide d'une boîte de relais ou du cavalier fourni.

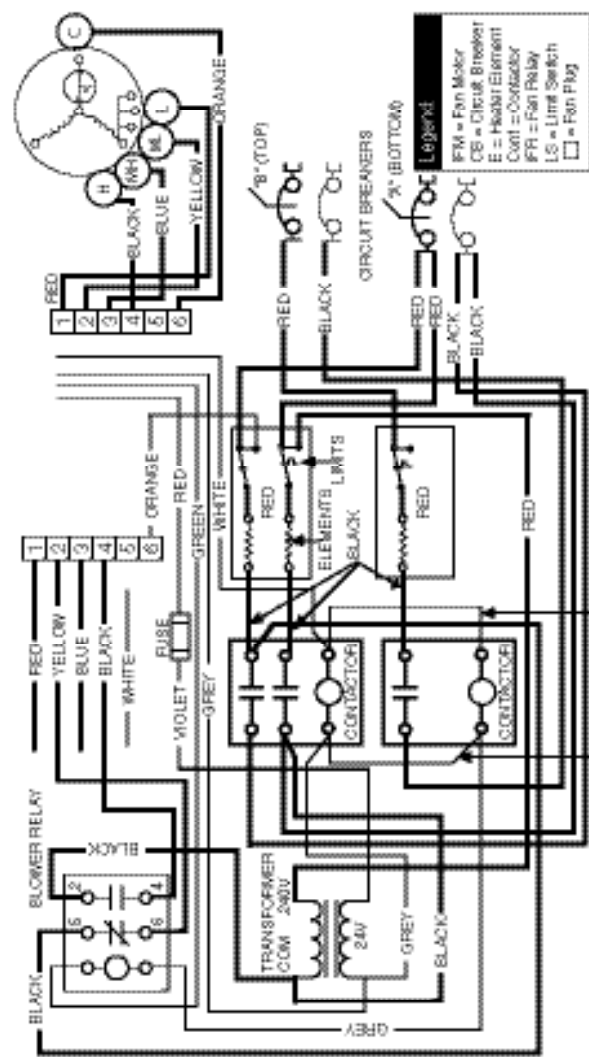

LEGEND:
 LOW VOLTAGE ———
 HIGH VOLTAGE ———

7112700
 01 13

Figure 24. E3EB-015H & E3EB-017H Models

WIRING DIAGRAM

Model: E3EB-020/023H

WARNING

Switch circuit breakers to the "off" position before servicing the furnace.

NOTES:

1. Supply wire size must be in accordance to the applicable revision of the NEC and all other applicable codes.
2. Thermostat anticipator setting: 0.40 Amps
3. To change blower speed on units without a relay box installed refer to installation instructions
4. Refer to furnace and/or relay box installation instructions for thermostat connections.
5. If any wire in this unit is to be replaced it must be replaced with 105° C thermoplastic copper wire of the same gauge.
6. Not suitable for use on systems exceeding 120V to ground.
7. Refer to installation instructions for complete wiring diagram.
8. Heating and cooling may be wired on the same speed using either a relay box or the provided jumper wire.

AVERTISSEMENT

Placez les disjoncteurs en position « off » avant d'intervenir la fournaise.

1. La taille du câblage d'alimentation doit être conforme à la révision applicable des codes NEC et des autres codes applicables.
2. Réglage d'anticipation du thermostat : 0,40 A
3. Pour changer la vitesse du ventilateur sur les unités sans boîte de relais, consultez les instructions d'installation.
4. Consultez les instructions d'installation de la fournaise ou de la boîte de relais pour les branchements du thermostat.
5. Si l'un ou l'autre des fils de cette unité requiert un remplacement, il doit être remplacé par un fil en cuivre thermoplastique 105 °C du même gabarit.
6. Ne convient pas à l'utilisation sur les systèmes qui excèdent 120 V à la terre.
7. Consultez les instructions d'installation pour un schéma de câblage complet.
8. Le chauffage et la climatisation peuvent être câblés sur la même vitesse à l'aide d'une boîte de relais ou du cavalier fourni.

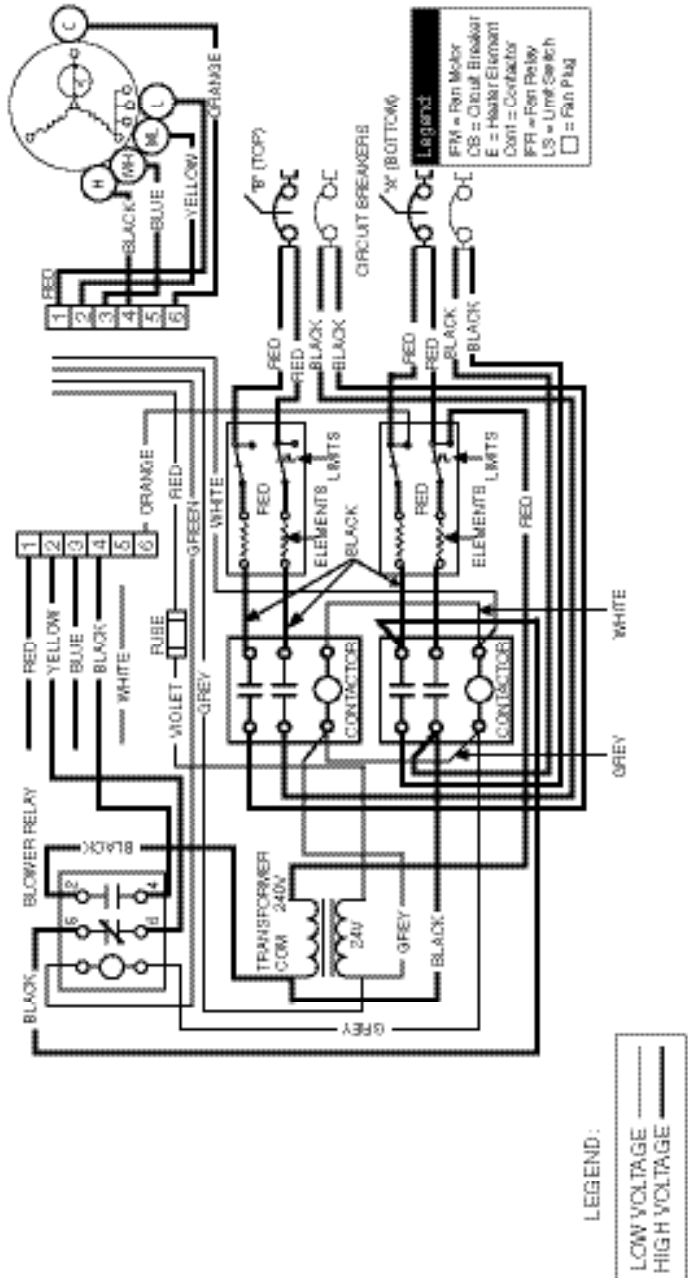

7112710
01/13

Figure 25. E3EB-020H, E3EB-023H, & E2EB-015HBR Models

INSTALLATION / PERFORMANCE CHECK LIST

| | | |
|--|--------|----|
| INSTALLER NAME: | | |
| CITY: | STATE: | |
| INSTALLATION ADDRESS: | | |
| CITY: | STATE: | |
| UNIT MODEL # | | |
| UNIT SERIAL # | | |
| MINIMUM CLEARANCES AS SHOWN IN FIGURE 1 (PAGE 5)? | YES | NO |
| HAS THE OWNER'S INFORMATION BEEN REVIEWED WITH THE HOME-OWNER? | YES | NO |
| HAS THE LITERATURE PACKAGE BEEN LEFT NEAR THE FURNACE? | YES | NO |

| ELECTRICAL SYSTEM | | |
|--|-----|----|
| ELECTRICAL CONNECTIONS TIGHT? | YES | NO |
| LINE VOLTAGE POLARITY CORRECT? | YES | NO |
| Supply Voltage: VOLTS | | |
| HAS THE THERMOSTAT BEEN CALIBRATED? | YES | NO |
| IS THE THERMOSTAT LEVEL? | YES | NO |
| IS THE FURNACE GROUNDED PROPERLY? | YES | NO |
| IS THE HEAT ANTICIPATOR SETTING CORRECT? | YES | NO |

| COMBUSTION AIR & VENTING SYSTEM | | |
|---|-----|----|
| IS THERE ADEQUATE FRESH AIR SUPPLY FOR VENTILATION? | YES | NO |
| FILTER(S) SECURED IN PLACE? | YES | NO |
| FILTER(S) CLEAN? | YES | NO |

PROPOSITION 65 WARNING:

WARNING: This product contains chemicals known to the state of California to cause cancer.

WARNING: This product contains chemicals known to the state of California to cause birth defects or other reproductive harm.

ATTENTION INSTALLERS:

It is your responsibility to know this product better than your customer. This includes being able to install the product according to strict safety guidelines and instructing the customer on how to operate and maintain the equipment for the life of the product. Safety should always be the deciding factor when installing this product and using common sense plays an important role as well. Pay attention to all safety warnings and any other special notes highlighted in the manual. Improper installation of the furnace or failure to follow safety warnings could result in serious injury, death, or property damage.

These instructions are primarily intended to assist qualified individuals experienced in the proper installation of this appliance. Some local codes require licensed installation/service personnel for this type of equipment. Please read all instructions carefully before starting the installation. Return these instructions to the customer's package for future reference.



Complies with H.U.D. Manufactured Home Construction & Safety Standards.

