

Submittal: DXH42FMK3IH**Flex Match Outdoor Unit**

Job Name:

Location:

Date:

Purchaser:

Engineer:

Submitted To:

For:

Unit Designation:

Schedule #:

Features:

- Inverter-driven Compressor and Fan
- Flared Piping Connections
- Wireless Remote Controller Included (Ductless)
- Anti-corrosion coils
- Intelligent defrost
- Auto-Restart
- Easy diagnosis
- Limited 5-year parts & 7-year

compressor warranty

**SYSTEM RATINGS**

Rated Cooling Capacity:	42,000
Minimum Cooling Capacity:	8,870
Maximum Cooling Capacity:	44,300
Rated Heating Capacity:	42,000
Minimum Heating Capacity:	8,870
Maximum Heating Capacity:	54,592
SEER:	21.0
EER:	13
HSPF:	10.0
COP:	13.3

Operating Ambient Temperature Range (°F)

Cooling (Min-Max):	-22 ~ 118
Heating (Min-Max):	-22 ~ 75

Power Supply

Voltage (Min-Max):	187/253
Minimum Circuit Ampacity (MCA):	30
Max. Overcurrent Protection (MOCP):	45

OUTDOOR UNIT DATA**Compressor**

Type:	Twin Rotary
RLA:	19.6

Fan Motor

Output Power:	130
FLA:	2.5
Air Flow CFM (Max):	3,413

Sound Pressure

61

Physical Characteristics**Dimensions:**

Width:	40.1
Height:	32.5
Depth:	16.8

Weight (Net lbs) 174.2

Refrigerant Piping Data

Refrigerant Type:	R-32
Pre-charged Amount (Oz):	95.2
Additional amount (Oz/ft.):	0.2

Submittal: DXH42FMK3IH

Outdoor Unit Dimensions

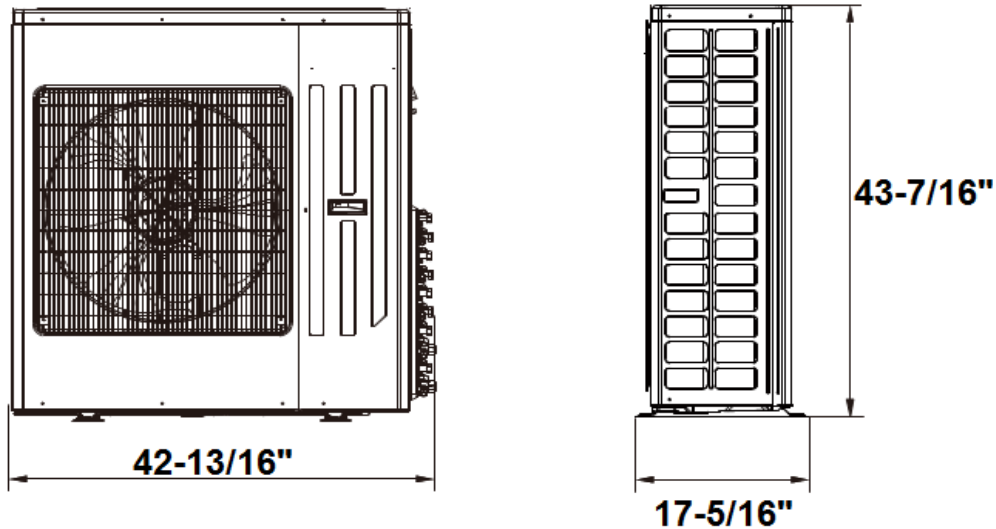

Outdoor Unit Piping Connection Size		
	"Liquid"	Gas
Circuit "A"	1/4"	3/8"
Circuit "B"	1/4"	3/8"
Circuit "C"	1/4"	3/8"
Circuit "D"	1/4"	3/8"
Circuit "E"	1/4"	3/8"

Outdoor Unit Minimum Clearances

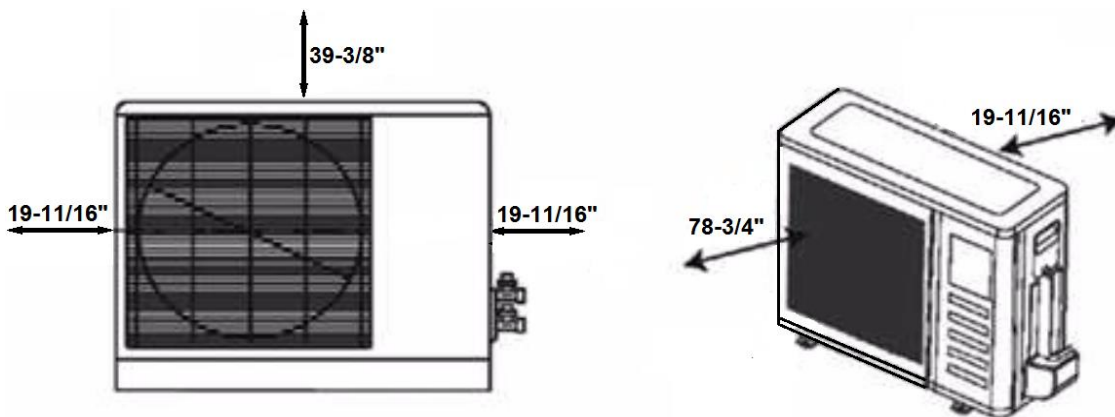

Specifications are subject to change without notice.

Submittal: DXH42FMK3IH

System Piping Length Information

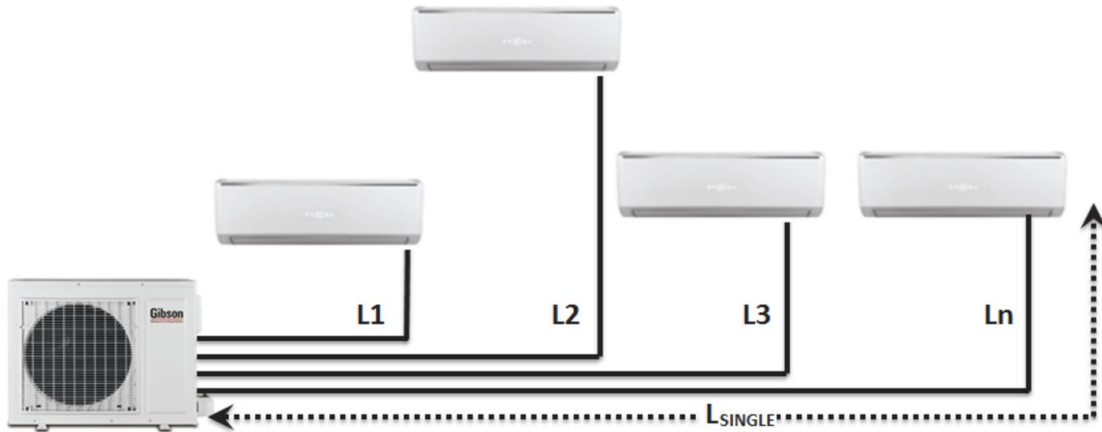

$$L_{TOTAL} = L1 + L2 + \dots + Ln$$

Model Number	Min. Piping Length Per Indoor Unit (Ln)	Max. Piping Length Per Indoor Unit (Ln)	Max. Total Piping Length (LTotal)
DXH18FMK3IH	32.81	65.62	131.23
DXH24FMK3IH	98.42	65.62	196.85
DXH30FMK3IH	131.23	82.02	262.46
DXH36FMK3IH	131.2	82.02	262.46
DXH42FMK3IH	164	82.02	328.08

"L" is the linear equivalent length of liquid line including elbows.

System Piping Height Difference Information

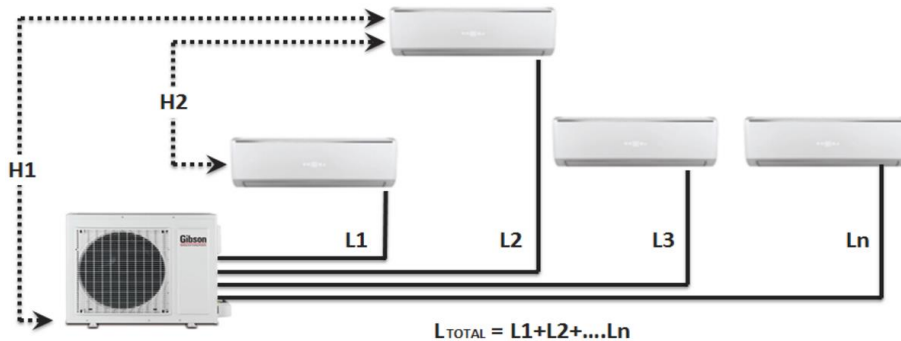

$$L_{TOTAL} = L1 + L2 + \dots + Ln$$

Model Number	Max. Height Difference Between Indoor and Outdoor Units (H1)	Max. Height Difference Between Indoor Units (H2)
DXH18FMK3IH	49.21	49.21
DXH24FMK3IH	49.21	49.21
DXH30FMK3IH	82.02	82.02
DXH36FMK3IH	82.02	82.02
DXH42FMK3IH	82.02	82.02

"H" is the difference in height measured from the piping connections.

Specifications & illustrations are subject to change without notice or incurring obligations.
O'Fallon, MO © Nordyne LLC 2024. All Rights Reserved. XXXXXX (11/24)

ODU SKU: 1049140